

FlexRadio Systems

FLEX-1500

Software Defined Radio

Service Manual



PRELIMINARY

Author: Graham Haddock, KE9H

Contents

<i>Introduction</i>	3
<i>Theory of Operation</i>	4
<i>Alignment, Test and Calibration.....</i>	11
<i>Troubleshooting and Diagnostics</i>	15
<i>Assembly and Disassembly.....</i>	16

Appendix “A” Schematic, PTRX (Transceiver) Board

Appendix “B” Schematic, PPA05 (RFPA) Board

Appendix “C” Boards, Top View.

Appendix “D” Test Points and Bus Access.

Appendix “E” Test Fixture.

Appendix “F” Bill of materials.

Introduction

The FLEX-1500™ QRP Software Defined Radio is both an entry level QRP radio and is also suited to be the ideal IF deck for VHF-Microwave operation. It provides all of the advantages of a software defined radio, including the sophisticated filters, panoramic spectrum displays and computer based Graphic interface characteristic of a Software defined Radio.

This service manual assumes that the reader / service technician is familiar with the operation of the radio and powerSDR control software. If additional information is required on those topics, please refer to the Product Manual and Quick Start Guide.



Front View - FLEX-1500

Theory of Operation

Refer to the Block Diagrams on the two following pages.

The Detailed Schematic is included in Appendix “A.”

The unit is powered by +13.8 Volts DC, supplied via the 2.5 mm x 5.5 mm coaxial power connector on the rear of the unit. The unit has an internal 3.0 Ampere fuse, that will blow if the unit draws excessive current, or if the polarity of the power connected to the unit is reversed.

The FLEX-1500 CPU (TAS1020B Streaming USB Controller) will communicate via USB for both control and streaming baseband data with the host CPU running the PowerSDR software. The CPU in the FLEX-1500 has control of all switching, signal routing, frequency generation via the DDS, FlexWire port, audio amplifier, as well as audio and baseband routing, CODEC clock generation, data conversion, gain and level controls for the radio.

Communication between the Flex-1500 radio and the host computer is via a USB connection capable of USB 1.1 or higher level USB operation. The protocol is USB “Full Speed” or 12 Megabits per second data transfer rate.

Power Systems and Distribution

The transceiver board requires a source of regulated +5 Volts at approximately 400 mA to function. +3.3 Volts is supplied to the board in general by a linear +3.3Volt regulator derived from the +5 Volt line. Additional +3.3 Volt and +1.8 Volts required to operate some of the integrated circuits is provided by point-of-load regulators in the vicinity of the IC.

Overall power for the unit is derived from the +13.8 Volt input on the RFPA board. This 13.8 Volts directly supplies the relays and power amplifier transistors. It is also feeds two regulators. A 6 Volt regulator is switched on when transmitting, and off when receiving. This switched +6 Volt output is used to bias the RF power transistors. A separate +5 Volt regulator supplies power for the SPI decoder and relay driver IC on the RFPA board, as well as supplies all +5 Volt power to the transceiver board (PTRX) via the board to board interconnect system.

System Block Diagram
FLEX-1500 TRX BOARD
 Version 2010 APR 05

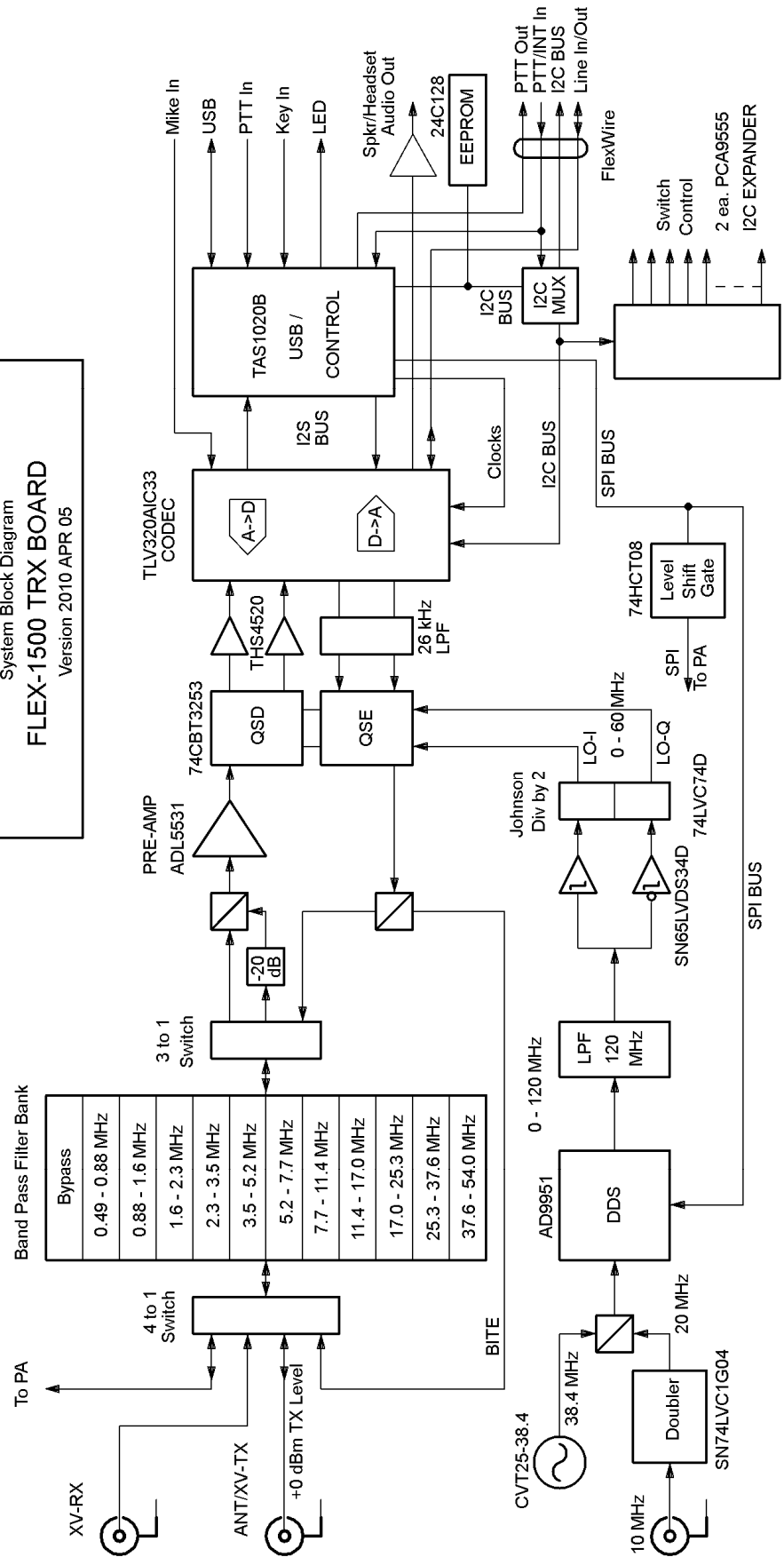

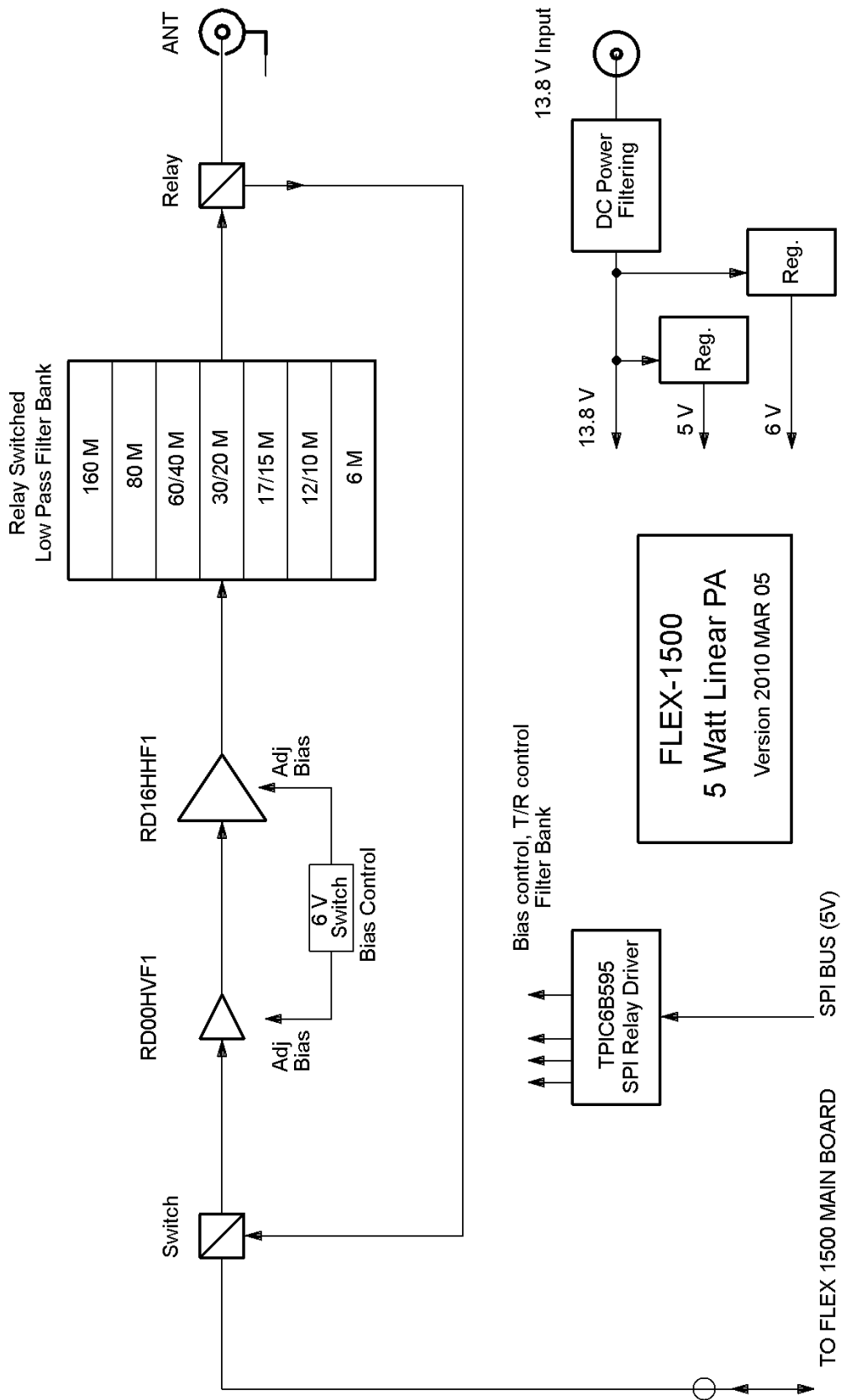

Control Busses

There are several control busses that interconnect the radio. A USB “Full Speed” bus interconnects the host computer running PowerSDR with the on-board CPU, the TAS1020B. Control from the TAS1020B CPU to the rest of the radio and external control is via an I2C bus system, and two each SPI busses.

Firmware for the CPU is resident in a local (I2C) EEPROM on the transceiver board. Upon power up, the CPU will look for the presence of a properly programmed EEPROM, load this code, begin execution, and register with the host computer as a FLEX-1500 device. In the absence of the EEPROM, or lack of correctly identified firmware, the CPU will execute from internal ROM, and identify itself to the host computer as a “TI DFU device.”

The FLEX-1500 CPU will communicate via USB for both control and streaming baseband data with the host CPU running the PowerSDR software. The CPU in the FLEX-1500 has control of all switching, signal routing, frequency generation via the DDS, FlexWire port, audio amplifier, as well as audio and baseband routing, CODEC clock generation, data conversion, gain and level controls for the radio. All of the above must be translated from local hardware and register controls to the Command and Data structures chosen for USB transport and interface in the host to the PowerSDR software.

I2C Bus

The I2C bus exists as three instances.

- (1.) The computer bus (I2C-C), which contains the (master) CPU, the EEPROM containing program memory and calibration parameters, and the Bus Mux.
- (2.) The Internal I2C bus, (I2C-I) containing the two bus expanders and the CODEC chip.
- (3.) The External I2C bus (I2C-E) which is routed to the FlexWire DB-9 connector, and is only used in conjunction with an external FlexWire device.

The I2C Bus Mux selects whether the Computer I2C bus will be connected to the Internal or External I2C bus extension at any given time, as well as passing any interrupt requests upwards to the CPU. Since the EEPROM and the Bus Mux are on the computer bus, their addresses will appear in all I2C bus spaces.

I2C Bus Structure

The I2C bus address values are provided according to the TI convention, where the address is an eight bit word, expressed as two hexadecimal characters. The least

significant bit is actually the ~read/write bit, but is always presented as a “0” when the address is expressed. The TAS1020B is the I2C Bus Master and is always connected to the I2C Multiplex Chip and the EEPROM.

When the Bus Multiplex is set to “Outside,” the I2C bus is routed to the appropriate pins on the FlexWire connector. When set to “Inside” the I2C bus is routed to the CODEC, and the two Bus Expanders, which convert I2C commands to many high/low outputs used to control the individual switches that control signal routing in the radio.

The Audio Amplifier is controlled by general purpose outputs from the CODEC.

SPI Bus

There is also a SPI bus, used to control the DDS and the RFPA. It appears as two physical instances, a 3.3V version and a 5V version. The SPI is outbound control only, for both the AD9951 DDS and RF PA board.

The AD9951 DDS is controlled via the 3.3 Volt SPI bus, directly from the CPU. The DDS will operate with either a 20 MHz or 38.4 MHz reference input.

The TPIC6B595 Relay Driver is controlled by the 5 Volt SPI bus, and controls the following relays according to the band of operation or transmit/receive status.

A “High” SPI control bit is the active state, which provides a LOW output from the relay driver to turn the relays ON.

I.C. Name	Bit	Pin	Name	Function	Initial
Drain0	0	4	15M	Active = 17 or 15 Meter Band	0 = Inactive
Drain1	1	5	160M	Active = 160 Meter Band	0 = Inactive
Drain2	2	6	20M	Active = 30 or 20 Meter Band	0 = Inactive
Drain3	3	7	6M	Active = 6 Meter Band	0 = Inactive
Drain4	4	14	80M	Active = 80 Meter Band	0 = Inactive
Drain5	5	15	10M	Active = 12 or 10 Meter Band	0 = Inactive
Drain6	6	16	XMIT	HIGH = Transmit mode, LOW = Receive mode	0 = Receive
Drain7	7	17	40M	Active = 60 or 40 Meter Band	0 = Inactive

RF Signal Processing

The incoming rf signals may be received via the antenna connector on the RFPA board, the transverter receive connector, or the transverter common connector. These signals are routed via the appropriate bandpass filter, then either directly to the preamp, or through a 20 dB pad to offset the gain of the preamp. The output of the preamp is fed to the QSD down-mixer, with an output of I and Q baseband signals in the range of 0 to 24 kHz.

The QSD down-mixer is also supplied with a quadrature local oscillator signal which is derived from the DDS. The DDS operates at twice the desired local oscillator signal, passes through a 120 MHz low pass filter, into a Johnson Counter that both divides the DDS frequency by two, as well as generates the two quadrature local oscillator signals.

In transmit, in a reverse manner, I-Q baseband signals from the CODEC in the baseband range of 0 to 24 kHz are supplied to the QSE, along with the quadrature local oscillator signals at the operating frequency, resulting in a direct QSE output on the final transmit frequency, which is routed via the bandpass filters to either the transverter output connector, or the input to the RFPA.

Baseband Processing

In the receive direction, output I and Q signals from the QSD are passed through a set of OpAmps that have 18 dB of signal gain and 28 kHz low pass filters, then sent to the CODEC for digitization and transmission to the host computer.

In transmit, analog I and Q signals output from the CODEC are filtered in a 26 kHz low pass filter to remove wideband digital noise, then sent to the QSE for up-mixing.

Communications

In the receive configuration, digitized I and Q signals from the CODEC, representing the received pass band, are transferred using the I2S protocol to the Streaming USB controller. This controller then transfers this information via the USB protocol to the host computer. Processed and demodulated audio is returned via the USB protocol to the controller, then transferred to the CODEC via I2S protocol for conversion into analog audio signals.

In transmit, configuration, digitized microphone audio signals from the CODEC are transferred using the I2S protocol to the Streaming USB controller. This controller then transfers this information via the USB protocol to the host computer. Processed transmit audio in a digital I and Q format is returned via the USB protocol to the controller, then transferred to the CODEC via I2S protocol for conversion into analog baseband signals to drive the QSE up-mixer.

In the BITE (Built In Test Equipment) configuration, digitized I and Q signals from the CODEC, representing the received pass band, are transferred using the I2S protocol to the Streaming USB controller. This controller then transfers this information via the USB protocol to the host computer. Transmit test signals in a digital I and Q format are sent via the USB protocol to the controller, then transferred to the CODEC via I2S protocol for conversion into analog baseband signals to drive the QSE up-mixer.

Audio Amplifier

An audio amplifier is present, capable of driving stereo headphones, or stereo powered speakers, in the Stereo configuration, or a monophonic speaker directly, in the Mono configuration. In stereo, each of the two amplifiers are carrying the appropriate left or right channel information, and driving a low power amplifier suitable for headphones or high impedance loads. In the Mono configuration, the two incoming stereo signals are mixed together to form a single mono signal, then this is fed to one amplifier directly, and inverted and fed to the other amplifier to form an “H-Bridge” speaker amplifier. In this mode the speaker must be wired to bridge the amplifier output (Connect to tip and ring on stereo speaker plug) with no connection to ground.

Alignment, Test and Calibration

The only manual alignment required is setting the quiescent bias for the RF power transistors on the RFPA (PPA05 PCB.)

All other alignment, test and calibration will occur using production test software built into PowerSDR.

Bias Adjustment

FLEX-1500 RFPA (PPA05) Bias settings

==

Power Supply Setup:
Adjust Power Supply to 13.8 Volts Output Voltage.

Adjust Power Supply Current Limit to 2.5 Amperes. To do this, place a short across the output terminals of the power supply and adjust the Output Current knob to read 2.5 Amps on the current meter.

==

The Bias settings are normally set with the PA board out of the radio. It does not have to be connected to the TRX board, since it is all DC settings, and you do not want any RF drive present.

With just the PA by itself on the workbench...

Plug in +13.8 Volts into the normal power connector.

To turn on the PA bias, ground the test point named "XMIT" at the lower right corner of the board, between K8 and K15. This will also activate relay K15, so you will hear a "click."

To measure current in the driver transistor, there is a one Ohm shunt resistor between test points DM- and DM+. Put a voltmeter that will give good readings in the range of 50 milliVolts across these two test points and normally, you would adjust R8 for 50 milliVolts plus minus 5 milliVolts, corresponding to 50 milliAmps flowing through driver transistor Q1.

(Hint: do not use long test probes that will go all the way through the PC board and touch the plate below. This will short the +13 Volts to ground, or destroy the metering resistor R2.)

After adjusting bias on Q1, adjust bias on Q3. The procedure with a cold plate will be to set total power drain to 530 mA, plus minus 25 ma, by adjusting R10.

You will see it drift some with temperature. With a hot base plate, it can rise as high a 580 mA.

Test and Calibration

FLEX-1500 Transceiver Final Assembly, Test and Calibration.

Required test equipment:

Host computer with PowerSDR version 2.0 or later and appropriate drivers for the FLEX-1500 and PowerMaster RF Powermeter installed.

USB Signal Generator, FlexRadio Systems model FLEX-1599

PowerMaster RF Power Meter model ____ with serial interface to host computer.

Loop-back test cable per accompanying diagram.

Suitable power and RF BNC connection cables.

Power Supply capable of supplying at least 2.5 Amperes at 13.8 Volts with current limit adjustable to 2.5 Amperes.

==

Power Supply Setup:

Adjust Power Supply to 13.8 Volts Output Voltage.

Adjust Power Supply Current Limit to 2.5 Amperes. To do this, place a short across the output terminals of the power supply and adjust the Output Current knob to read 2.5 Amps on the current meter.

==

Check for the presence of the latest version of the radio Firmware from the FlexRadio Systems SVN.

If not a current version of the radio firmware, use “Firmware Updater” to install and update the latest version of firmware

==

If there is any question as to whether the quiescent bias currents are properly set on the RFPA power transistors, they should be set prior to performing the PA calibration tests.

==

Plug the BNC-Coaxial cable from the PowerMaster watt meter into the BNC connector on the RFPA.

Plug the USB cable from the computer into the USB connector on the front edge of the PTRX board.

Plug the Powered speaker plug into the Speaker jack on the PTRX front edge.

Plug the loop-back test cable into the FlexWire DB-9 connector on the rear card edge, and the Key and Mike connectors into the connectors on the front card edge.

(Until full automatic test software is available, the speaker plug on the loop back test cable will be not be used.)

Plug in the +13.8 Volt power connector into the power connector on the RFPA.

==

Turn on the power switch on the PTRX board. The Blue LED should light within two seconds.

Open PowerSDR 2.0

Press "Start"

Note that the program is running and a moving noise floor appears.

Turn up the volume control to verify that noise comes out of the speakers, and the audio amplifier is operating. Return the volume control to "0".

Bring up the production test screen by pressing Control-Shift-P.

Check that the appropriate Com Port for the PowerMaster RF Power Meter is indicated.

The fully automated sequence of tests may be started, or the individual tests run for diagnostic purposes.

Press "Dot"

Press "DASH"

Press "PTT"

Press "Mike"

Press "Balance"
Press "Attenuator"
Press "Filter"
Press "Level"

(Additional tests will be added as additional test software is completed.)

If all tests are passed, as indicated by all green buttons,

Press "PA" to perform full calibration of the RFPA on all bands.

If this final test is passed, then radio level testing of the assembled radio is complete.

Close Production Test window, Stop PowerSDR, close PowerSDR, turn off power Switch on PTRX, Remove cables from Radio Assembly.

==

Troubleshooting and Diagnostics

For bench testing the complete unit or RFPA as a stand alone board, it is recommended that a 13.8 Volt current limited bench supply is used, with the current limiter set to 2.5 Amperes.

If necessary to test a transceiver board as a stand alone board, a holding fixture with number 4 corner pins can be used to hold the board. A source of regulated +5.0 Volts, current limited at 600 mA may be applied in place of the power source jumper on Jxxx.

The results from the software tests built into PowerSDR should provide direction as to any failures in the radio.

The blue light in the center of the power-on switch is controlled by the CPU. This light will only light if the CPU has downloaded valid firmware from the EEPROM and completed initialization.

If no blue light, check all voltages, including the output of the dedicated +3.3V regulator feeding the CPU digital power pins, which is separate from the general 3.3V regulator.

If the blue light is present, but the unit will not enumerate on the USB host, check cables, connectors, and proper voltage output from the dedicated +3.3V regulator feeding the CPU digital power pins.

None of the band pass filters in the transceiver board should have an insertion loss greater than 6 dB inside the band pass, so signal tracing with an RF signal generator and level meter or spectrum analyzer is very practical.

Excessive filter loss is usually associated with an incorrect inductance value.

Assembly and Disassembly

Required tools

Number 1 Phillips and number 2 Phillips screwdrivers are needed, and a nut driver to remove the DB-9 retention nuts.

Disassembly

Remove the two retention nuts on either side of the FlexWire DB-9 connector.

Remove the four corner screws on both the front and back covers using the number 2 Phillips screwdriver.

Observe the position of the upper PCB, it is in the fourth card slot. That is, three empty slots are above it. Observe the position of the two screw clearance holes on the bottom of the case. These holes are not equally spaced from the ends. The hole furthest from the edge is on the rear end (end with all BNCs.)

Remove the four bottom feet, using the number 1 Phillips screwdriver.

Gently slide both cards toward the rear panel, the one with all the BNC's until the connected pair of cards are clear of the outer case. The two cards may be separated.

Re-assembly

Reconnect the cards with the ten pin card to card connector.

Orient the case so that the rear of the case (end with screw clearance hole spaced furthest from the edge) is upwards.

Lower the upper board into the fourth board slot from the top of the housing. Once the upper board engages the side rails by an inch or two, then lower the lower board and heat spreader plate into the box and engage the board to board to board connection. The lower (PA board) should not engage any board slots, and will just roughly center in the bottom of the case. Gently slide in the pair of cards, until fully inside the new case.

Check that the two transistor mounting screws in the heat spreader are visible / roughly centered in the screw clearance relief holes in the bottom of the case.

Install the four feet using the number 1 Phillips screwdriver.

Install the front and rear panels, using the black #6 pan head screws, with a number # 6 flat washer under each screw head, with the number 2 Phillips screwdriver.

Install the two retention nuts on either side of the DB-9 connector.

Appendix "A"

Schematic, PTRX (Transceiver) Board

System Block Diagram
FLEX-1500 TRX BOARD
 Version 2010 APR 05

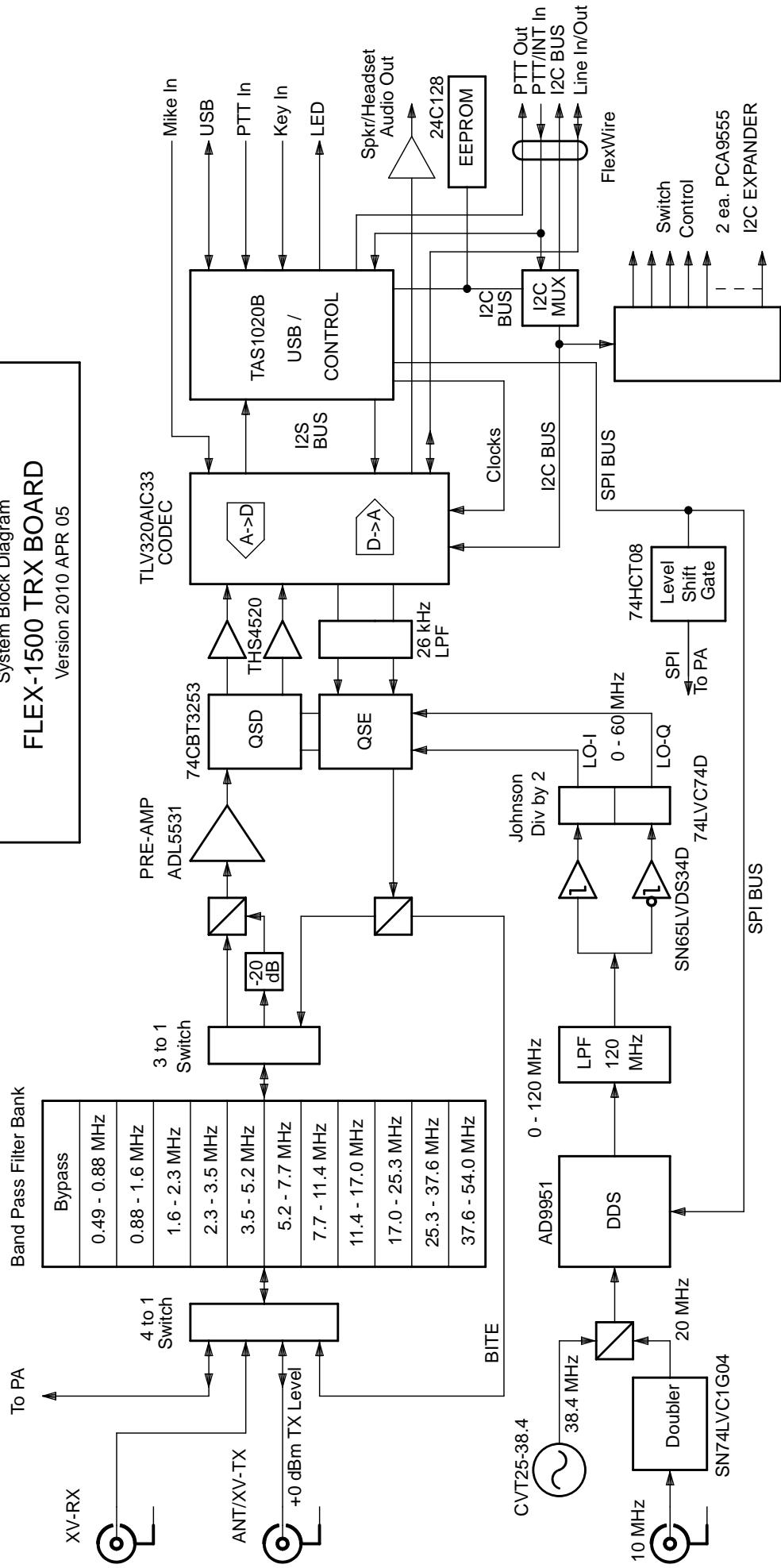

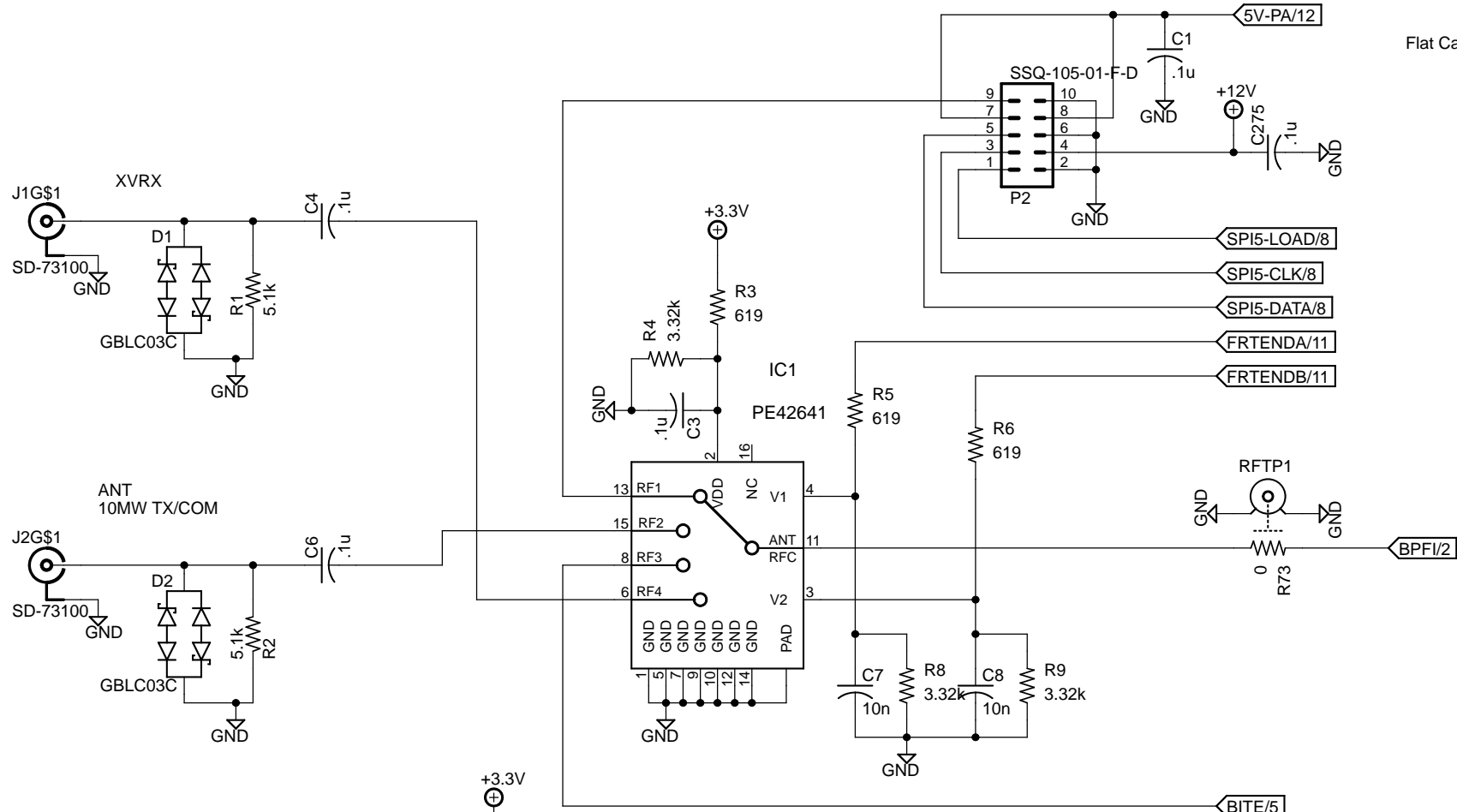

- Flat Cable Assignments
- 1.) SPI5-LOAD
 - 2.) Ground
 - 3.) SPI5-CLK
 - 4.) +12V
 - 5.) SPI5-DATA
 - 6.) Ground
 - 7.) +5
 - 8.) +5
 - 9.) RF
 - 10.) Ground

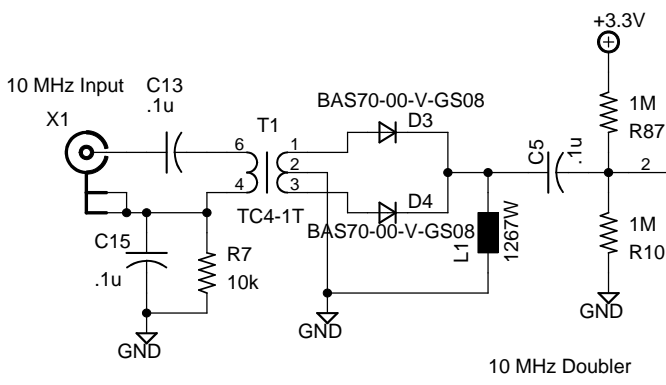

Test 10 MHz Multiplier

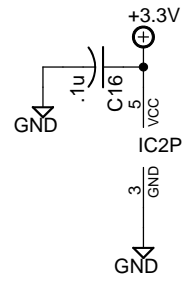

<h2>FRONT END</h2>	
Copyright FlexRadio Systems 2009, 2010	
TITLE: PTRX PC-0048 REV C	
Document Number:	REV:
Date: 3/26/2010 4:49:28 PM	Sheet: 1/14

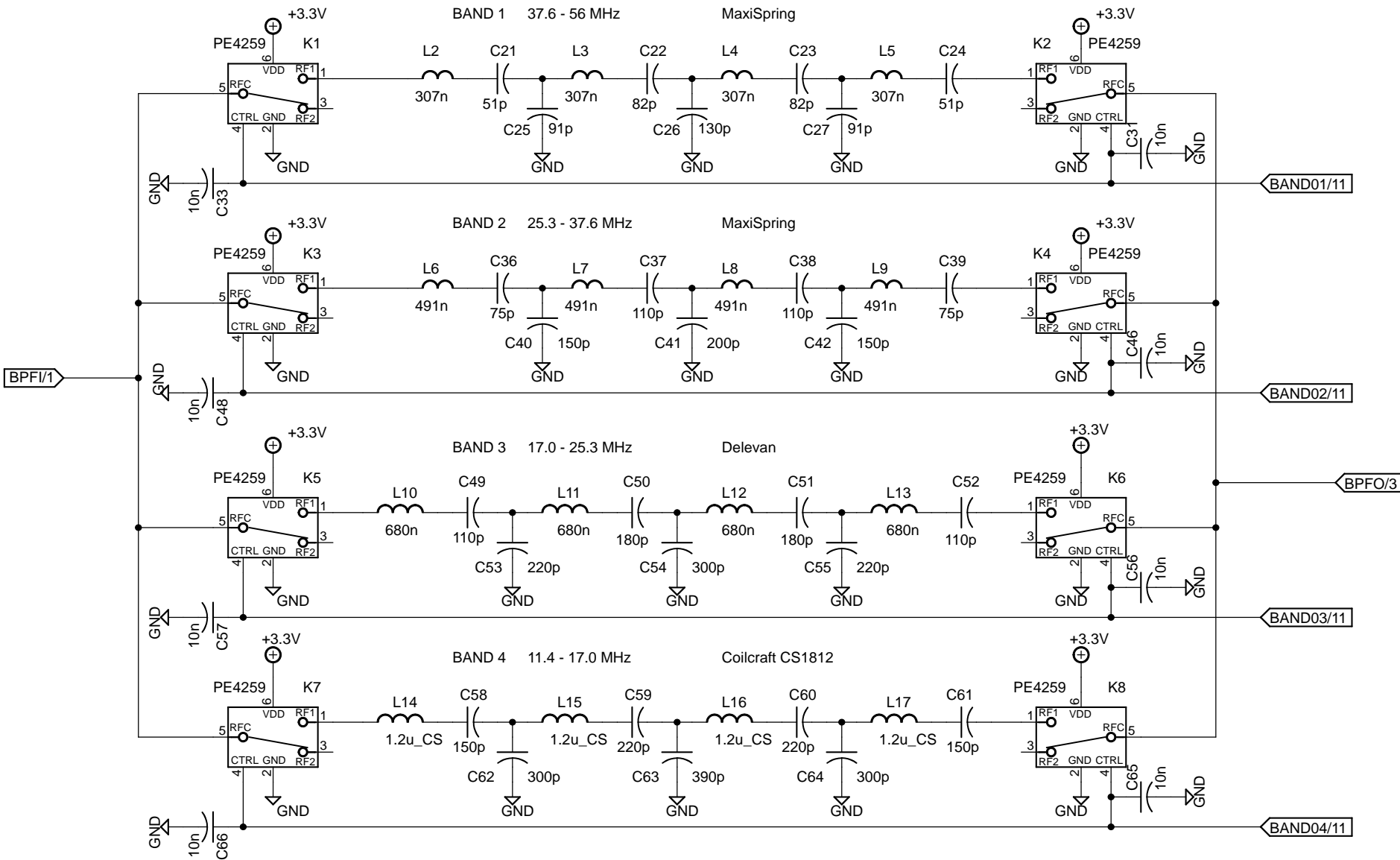

Physical Position on PCB:

- Band 4 - 11.4 - 17.0 MHz
- Band 8 - 2.3 - 3.5 MHz
- Band 2 - 25.3 - 37.6 MHz
- Band 5 - 7.7 - 11.4 MHz
- Band 9 - 1.6 - 2.3 MHz
- Band 1 - 37.6 - 56.0 MHz
- Band 12 - Bypass
- Band 6 - 5.2 - 7.7 MHz
- Band 10 - 0.88 - 1.6 MHz
- Band 3 - 17.0 - 25.3 MHz
- Band 7 - 3.5 - 5.2 MHz
- Band 11 - 0.49 - 0.88 MHz

BANDPASS FILTER BANK - HIGH

Copyright FlexRadio Systems 2009

TITLE: PTRX PC-0048 REV C

Document Number:

REV:

Date: 3/26/2010 4:49:28 PM

Sheet: 2/14

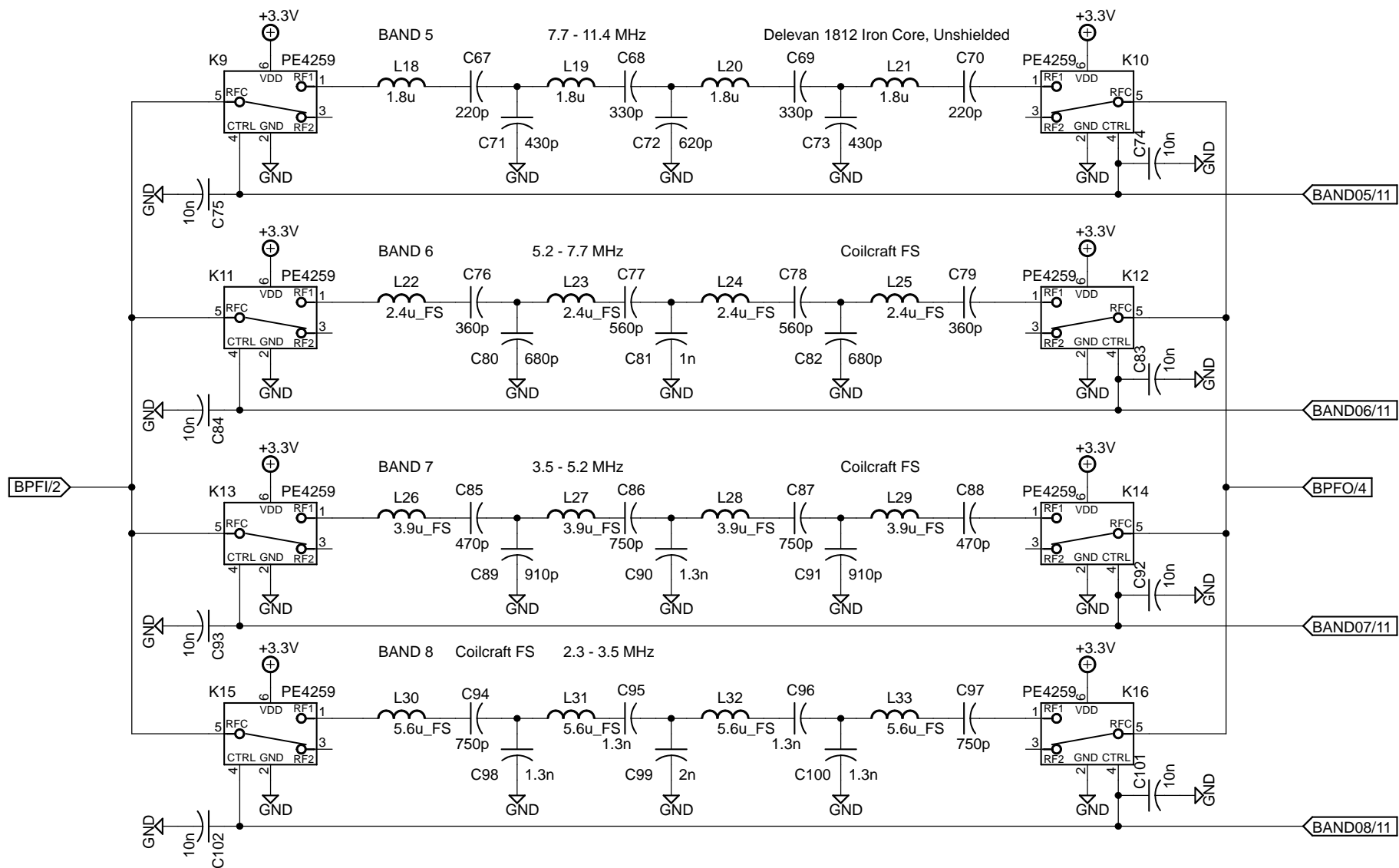

BANDPASS FILTER BANK - MIDDLE

Copyright FlexRadio Systems 2009

TITLE: PTRX PC-0048 REV C

Document Number:

REV:

Date: 3/26/2010 4:49:28 PM

Sheet: 3/14

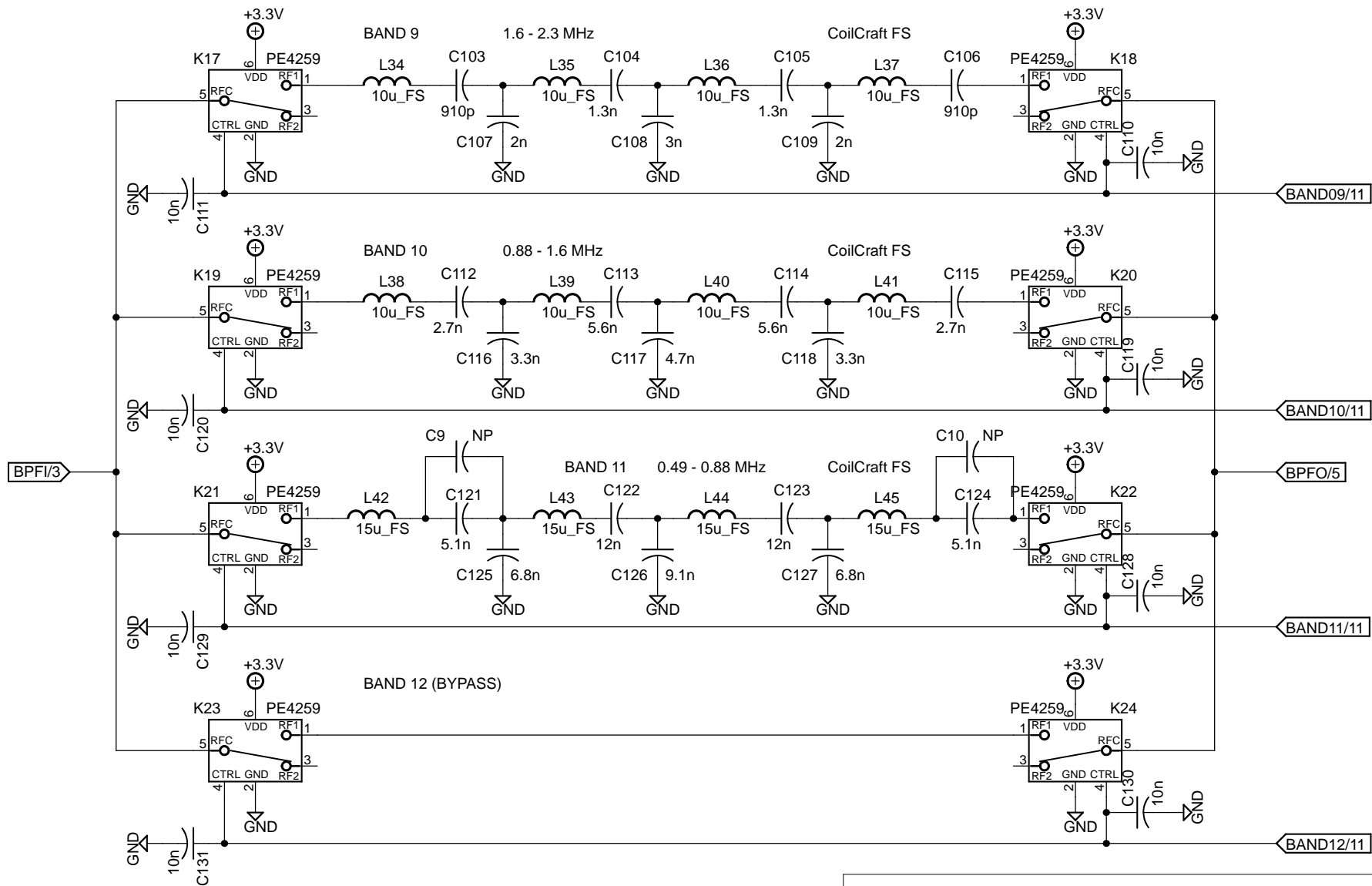

Note: 5.1n = 1.8n + 3.3n

BANDPASS FILTER BANK - LOW

Copyright FlexRadio Systems 2009

TITLE: PTRX PC-0048 REV C

Document Number:

REV:

Date: 3/26/2010 4:49:28 PM

Sheet: 4/14

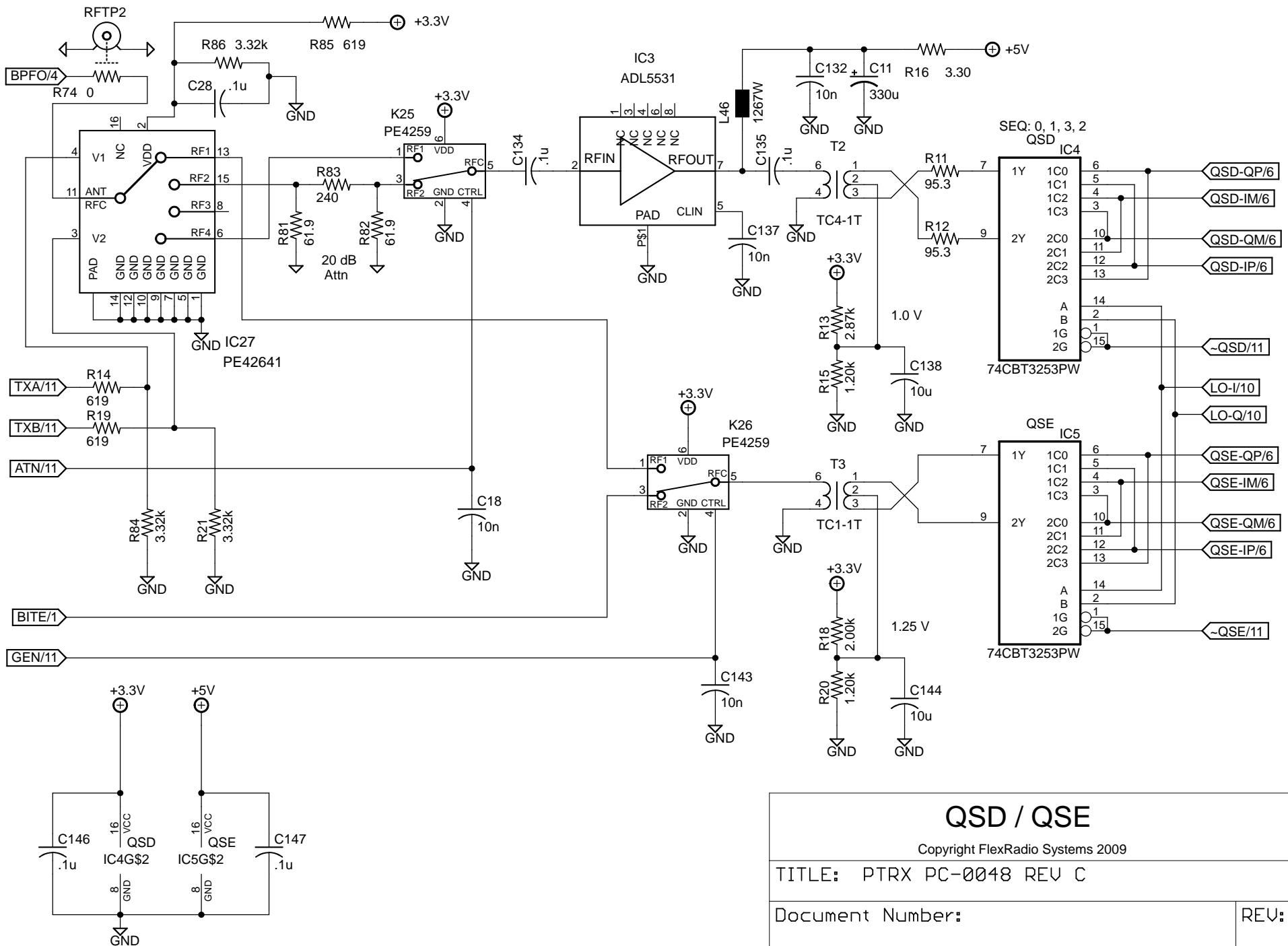

QSD / QSE

Copyright FlexRadio Systems 2009

TITLE: PTRX PC-0048 REV C

Document Number: _____ REV: _____

Date: 3/26/2010 4:49:28 PM

Sheet: 5/14

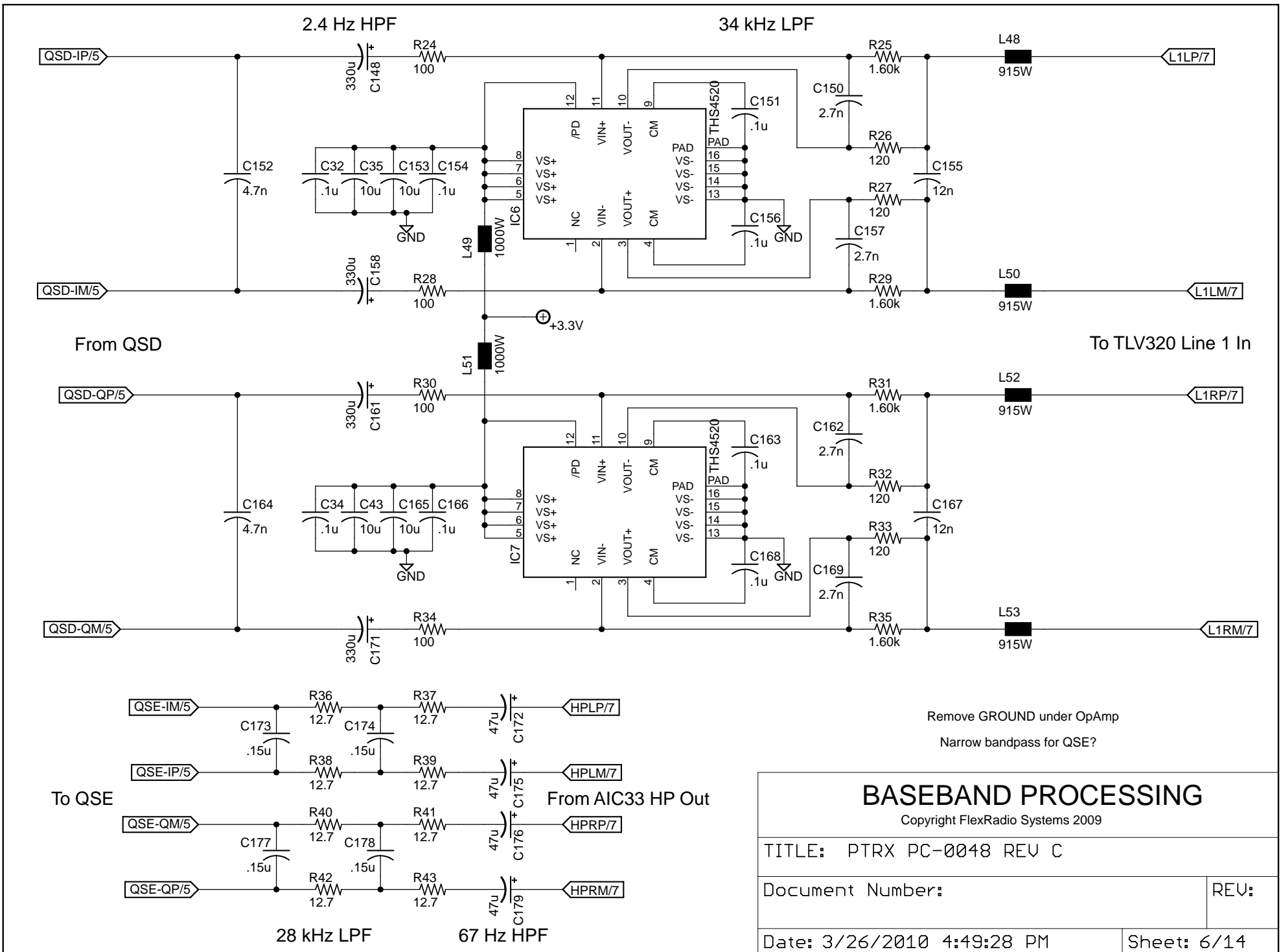

BASEBAND PROCESSING	
Copyright FlexRadio Systems 2009	
TITLE: PTRX PC-0048 REV C	
Document Number:	REV:
Date: 3/26/2010 4:49:28 PM	Sheet: 6/14

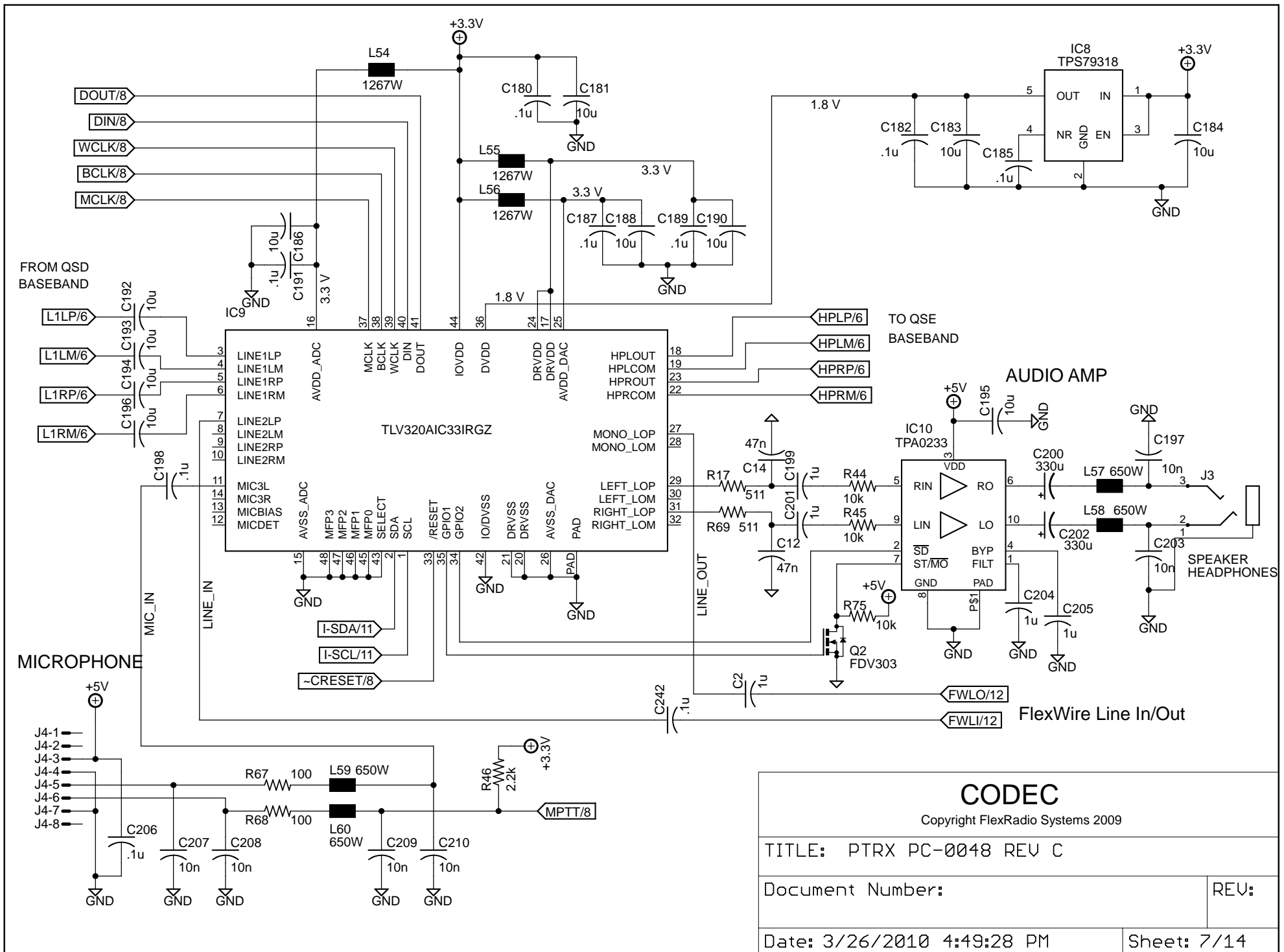

CODEC

Copyright FlexRadio Systems 2009

TITLE: PTRX PC-0048 REV C

Document Number:

REV:

Date: 3/26/2010 4:49:28 PM

Sheet: 7/14

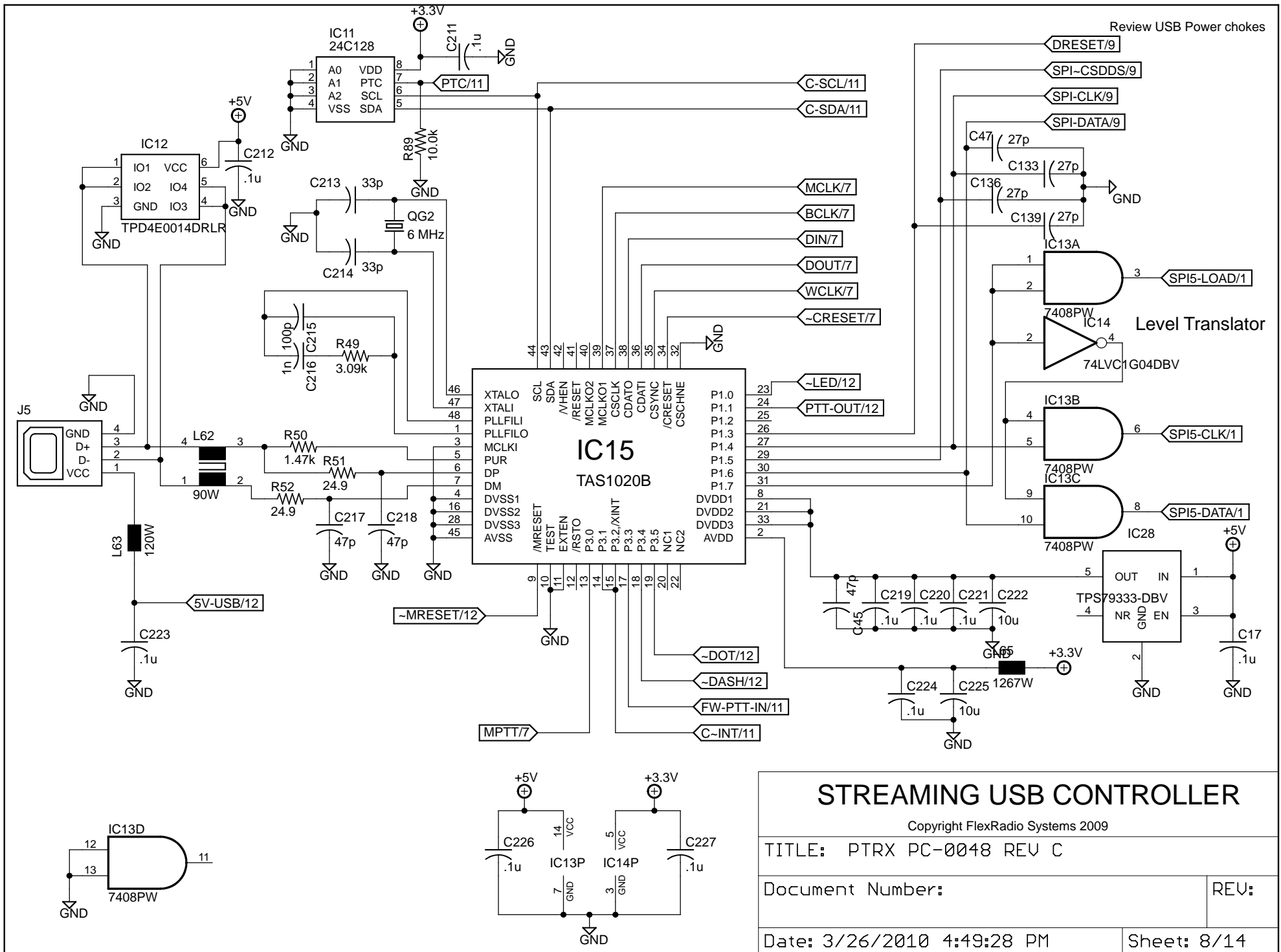

STREAMING USB CONTROLLER

Copyright FlexRadio Systems 2009

TITLE: PTRX PC-0048 REV C

Document Number: REV:

Date: 3/26/2010 4:49:28 PM Sheet: 8/14

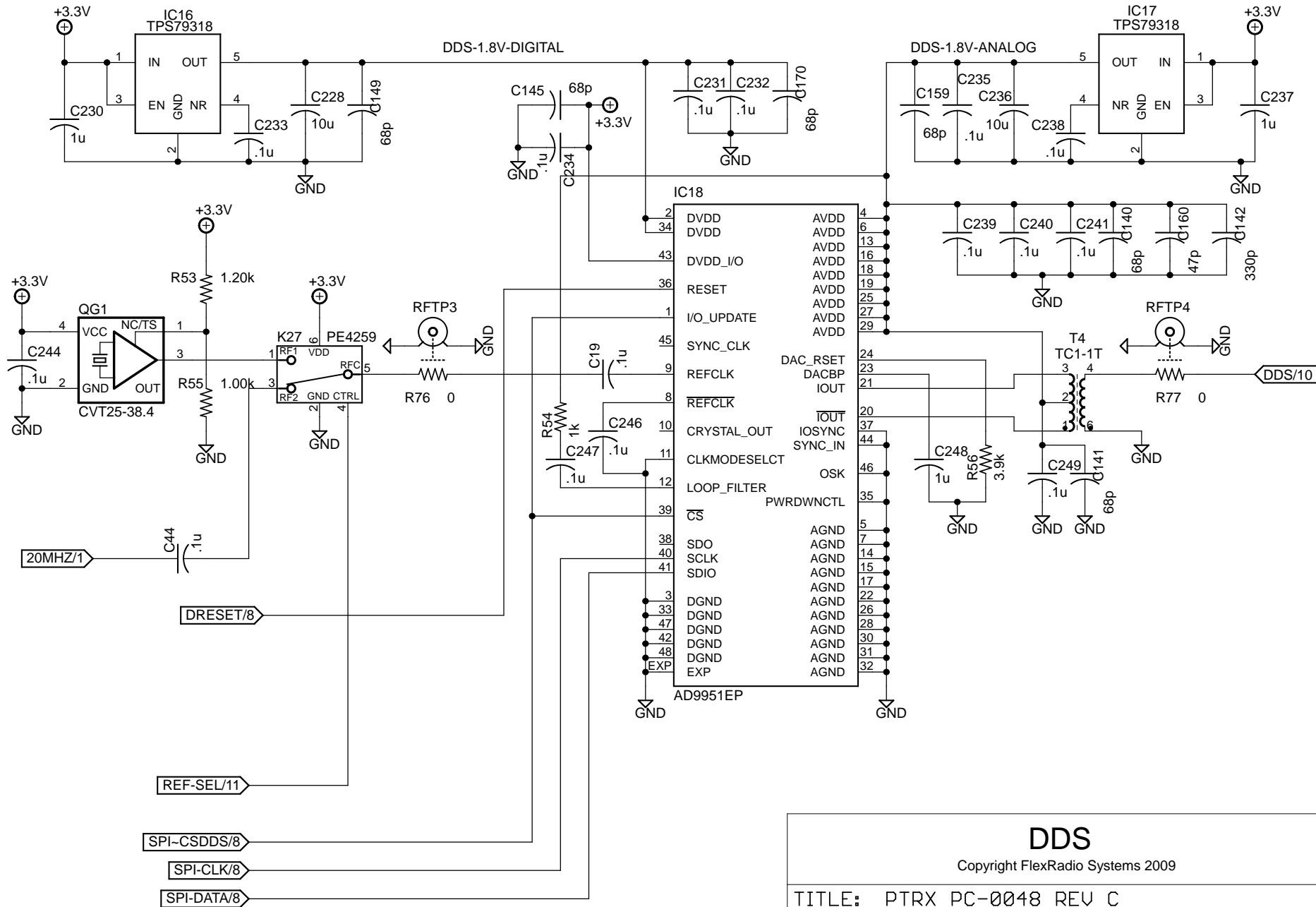

DDS

Copyright FlexRadio Systems 2009

TITLE: PTRX PC-0048 REV C	
Document Number:	REV:
Date: 3/26/2010 4:49:28 PM	Sheet: 9/14

Changed T5 to TC4-1T

Changed IC20 to SN65LVDS34D

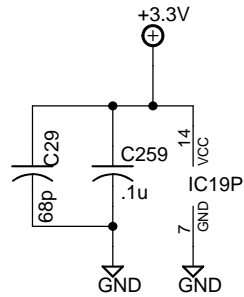
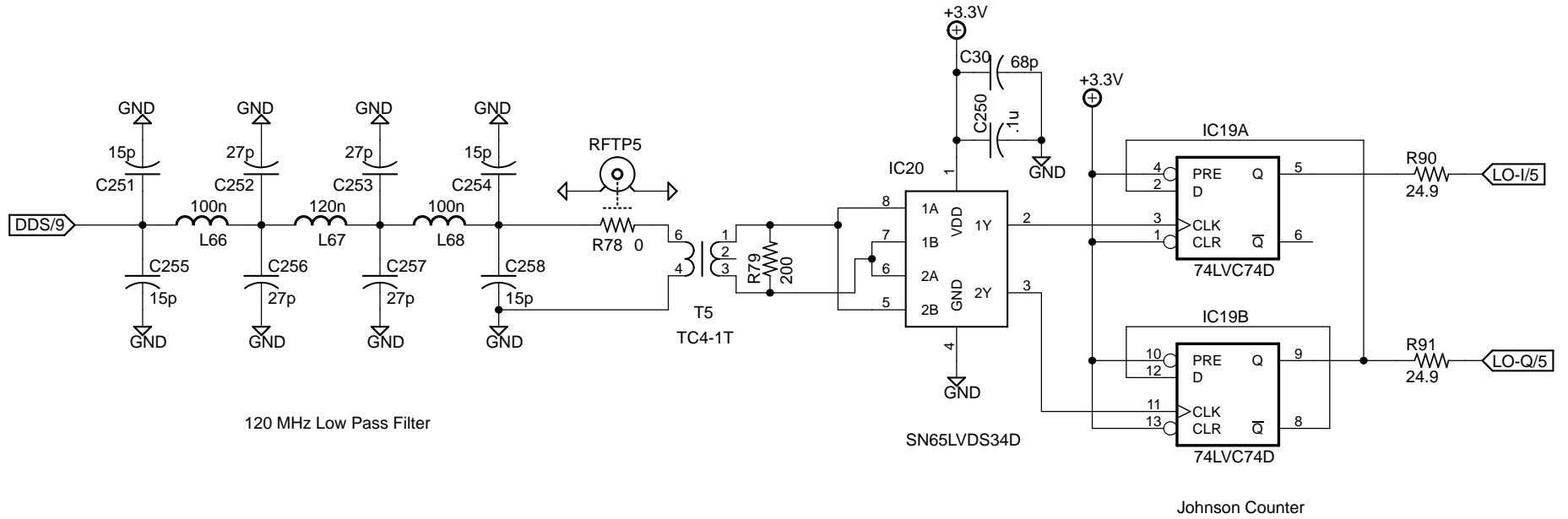

LO QUADRATURE GENERATOR

Copyright FlexRadio Systems 2009

TITLE: PTRX PC-0048 REV C

Document Number:

REV:

Date: 3/26/2010 4:49:28 PM

Sheet: 10/14

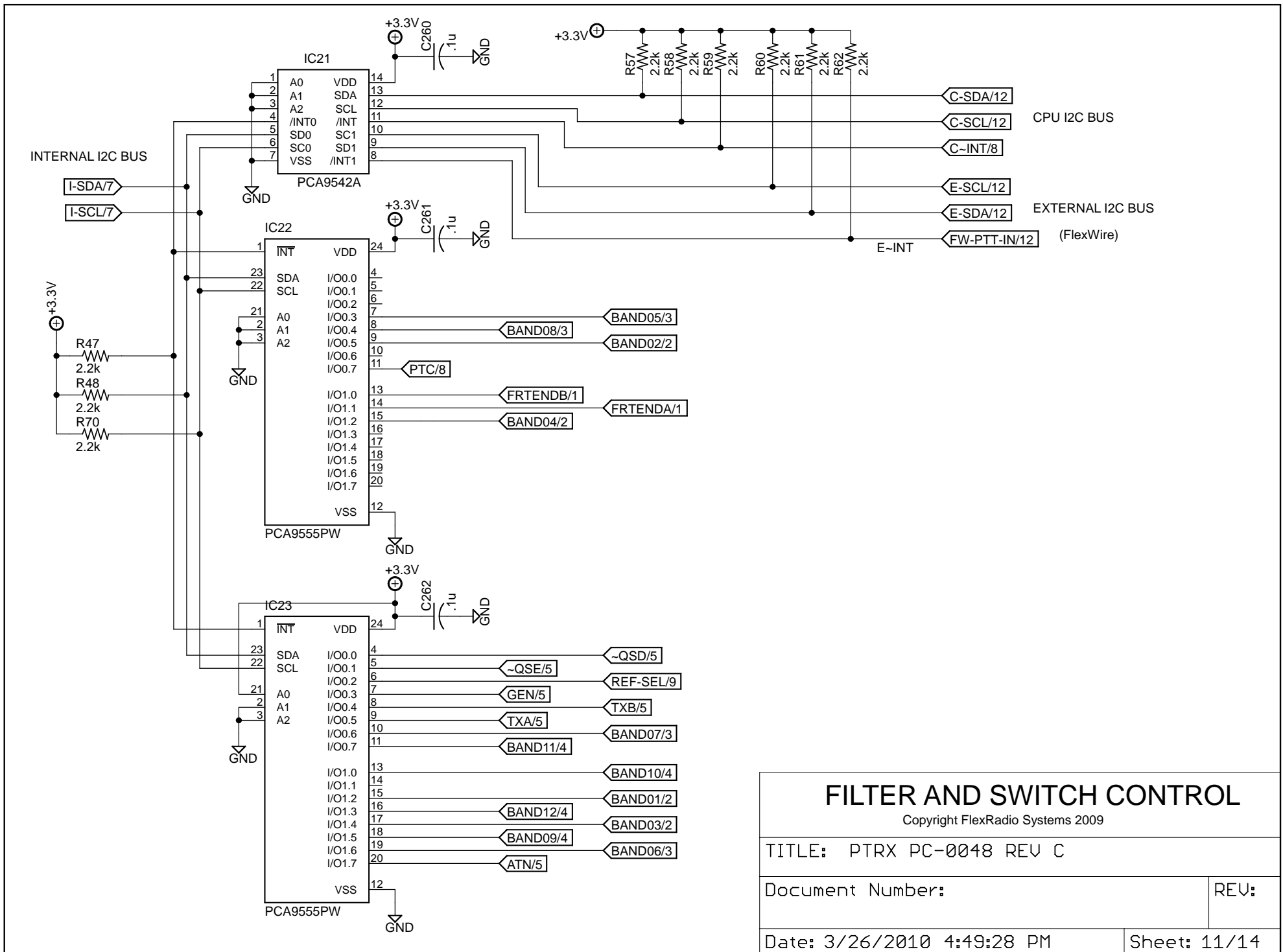

FILTER AND SWITCH CONTROL

Copyright FlexRadio Systems 2009

TITLE: PTRX PC-0048 REV C

Document Number:

REV:

Date: 3/26/2010 4:49:28 PM

Sheet: 11/14

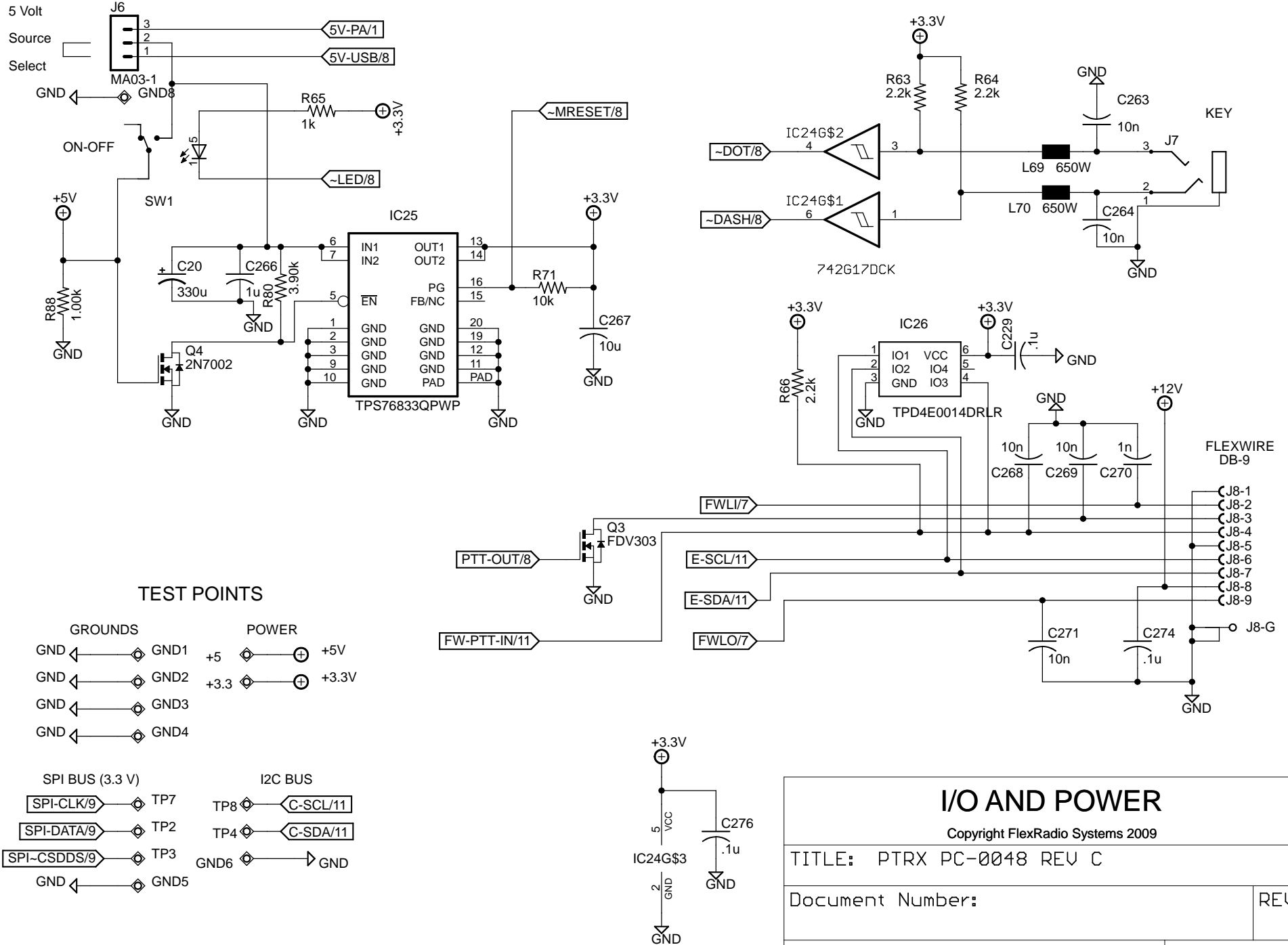

I/O AND POWER

Copyright FlexRadio Systems 2009

TITLE: PTRX PC-0048 REV C

Document Number:

REV:

Date: 3/26/2010 4:49:28 PM

Sheet: 12/14

Flat Cable Assignments

- 1.) SPI5-LOAD
- 2.) Ground
- 3.) SPI5-CLK
- 4.) +12V
- 5.) SPI5-DATA
- 6.) Ground
- 7.) +5
- 8.) +5
- 9.) RF
- 10.) Ground

Mike Connector Assignments

- 1.) N.C.
- 2.) N.C.
- 3.) Mike Bias (+5V)
- 4.) Mike Ground
- 5.) Mike In
- 6.) Mike PTT In
- 7.) Ground
- 8.) N.C.

FlexWire Assignments

- 1.) Ground
- 2.) LINE INPUT
- 3.) PTT OUT (New, was GND)
- 4.) PTT IN (New, was interrupt)
- 5.) Ground
- 6.) I2C-SCL
- 7.) I2C-SDA
- 8.) +5 Volts Out (New, was +13V)
- 9.) LINE OUT

SPI (DDS) BRIDGE ASSIGNMENTS

Individual holes for 0.025 in. square pins
1 x 4 pattern on 0.1 in. grid

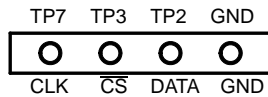

CODEC BRIDGE ASSIGNMENTS

Individual holes for 0.025 in. square pins
2 x 3 pattern on 0.1 in. grid

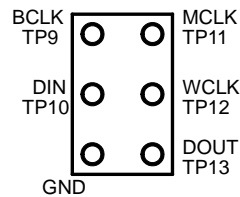

I2C ADDRESS ASSIGNMENTS

- 1.) USB / CPU - I2C MASTER ONLY
- 2.) CODEC - 0011 0000
- 3.) EEPROM - 1010 0000
- 4.) I2C MUX - 1110 0000
- 5.) EXPANDER 0 - 0100 0000
- 6.) EXPANDER 1 - 0100 0010

I2C (INTERNAL COMPUTER) BRIDGE ASSIGNMENTS

1 x 3 pattern on 0.1 in. grid

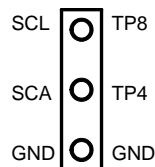

NOTE: Jumper SCA to GND to remove EEPROM from address space

PORT AND CONNECTOR DEFINITIONS

Copyright FlexRadio Systems 2009

TITLE: PTRX PC-0048 REV C

Document Number:

REV:

Date: 3/26/2010 4:49:28 PM

Sheet: 13/14

Appendix "B"

Schematic, PPA05 (RFPA) Board

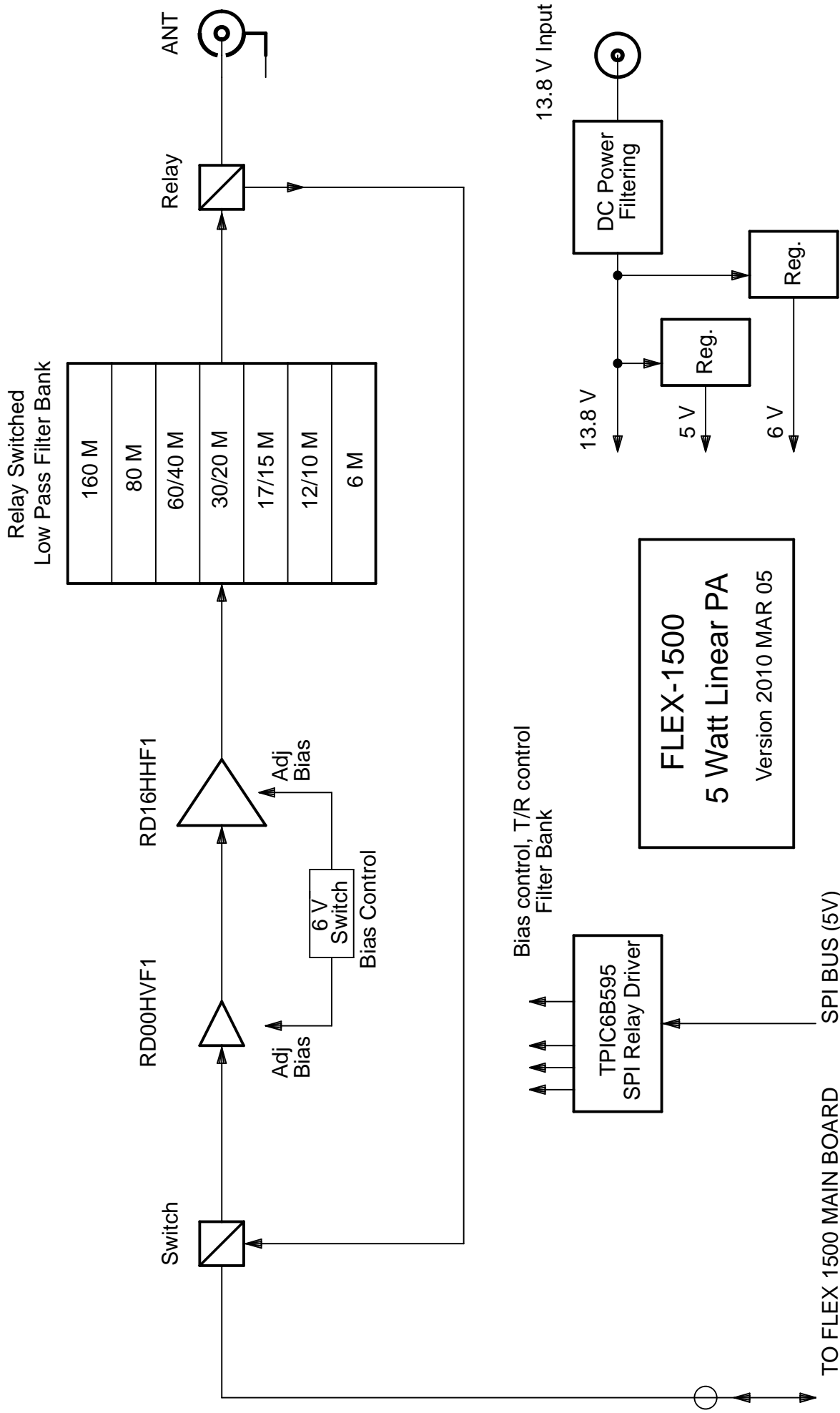

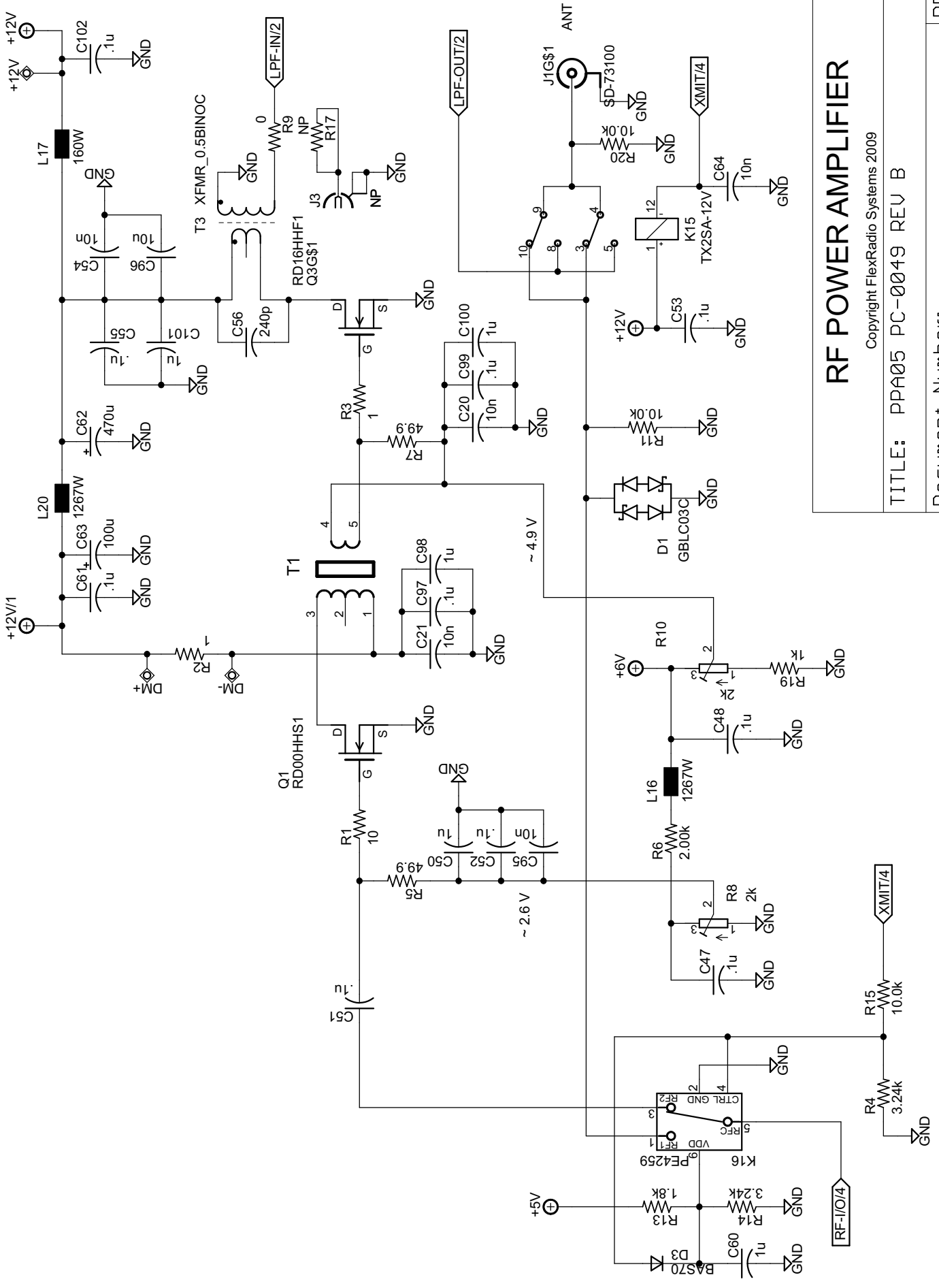

RF POWER AMPLIFIER

Copyright FlexRadio Systems 2009

TITLE: PPA05 PC-0049 REV B

Document Number:

REV:

Date: 3/25/2010 10:32:14 AM

Sheet: 1/4

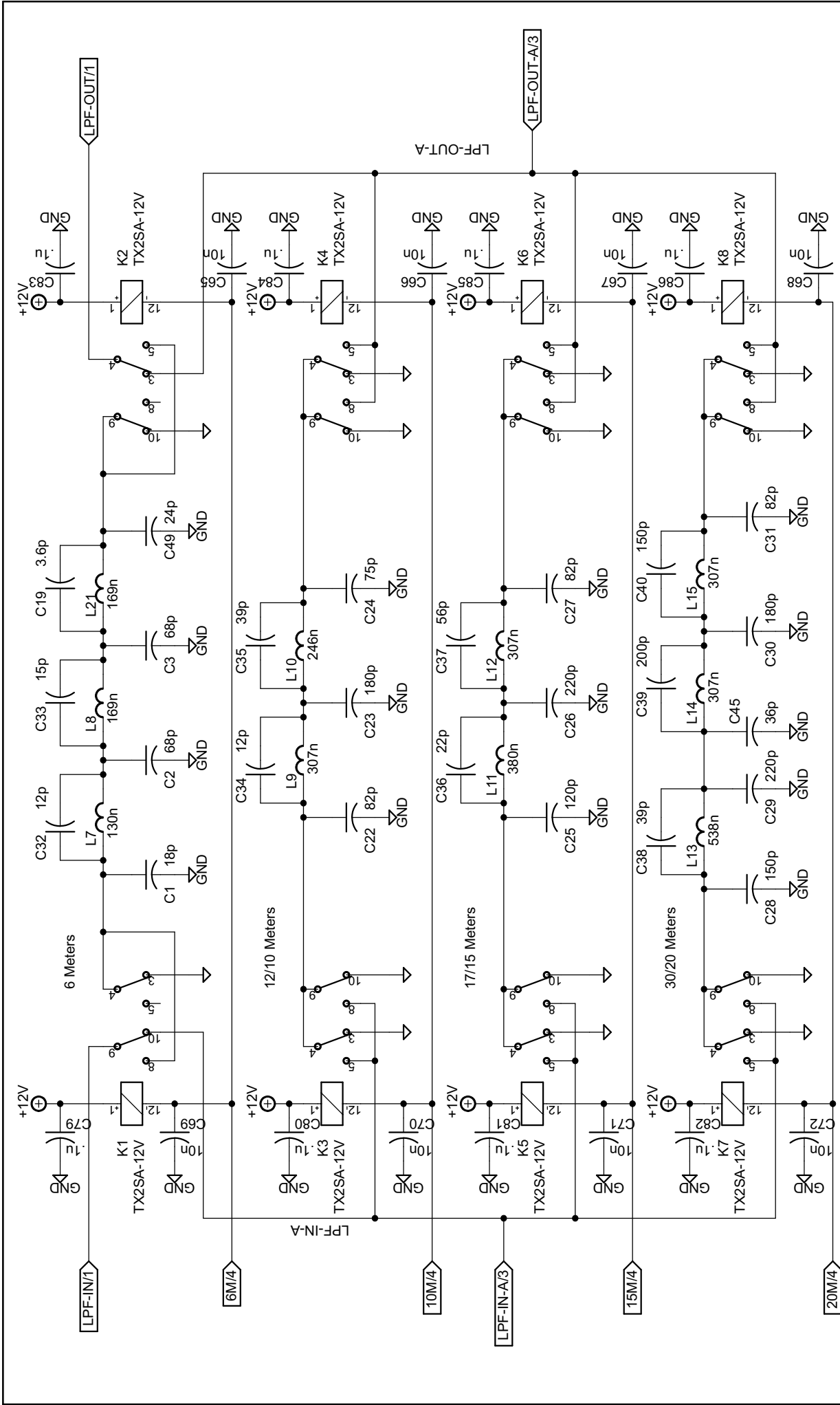

HIGH FREQUENCY LPF BANK	
Copyright FlexRadio Systems 2009	
TITLE: PPA05 PC-0049 REV B	
Document Number:	REV:
Date: 3/25/2010 10:32:14 AM	Sheet: 2/4

Physical order on board is:

- 60/40 M
- 10 M
- 80 M
- 17/15 M
- 160 M
- 30/20 M
- 6 M

All coils this page are
CoilCraft MaxiSpring

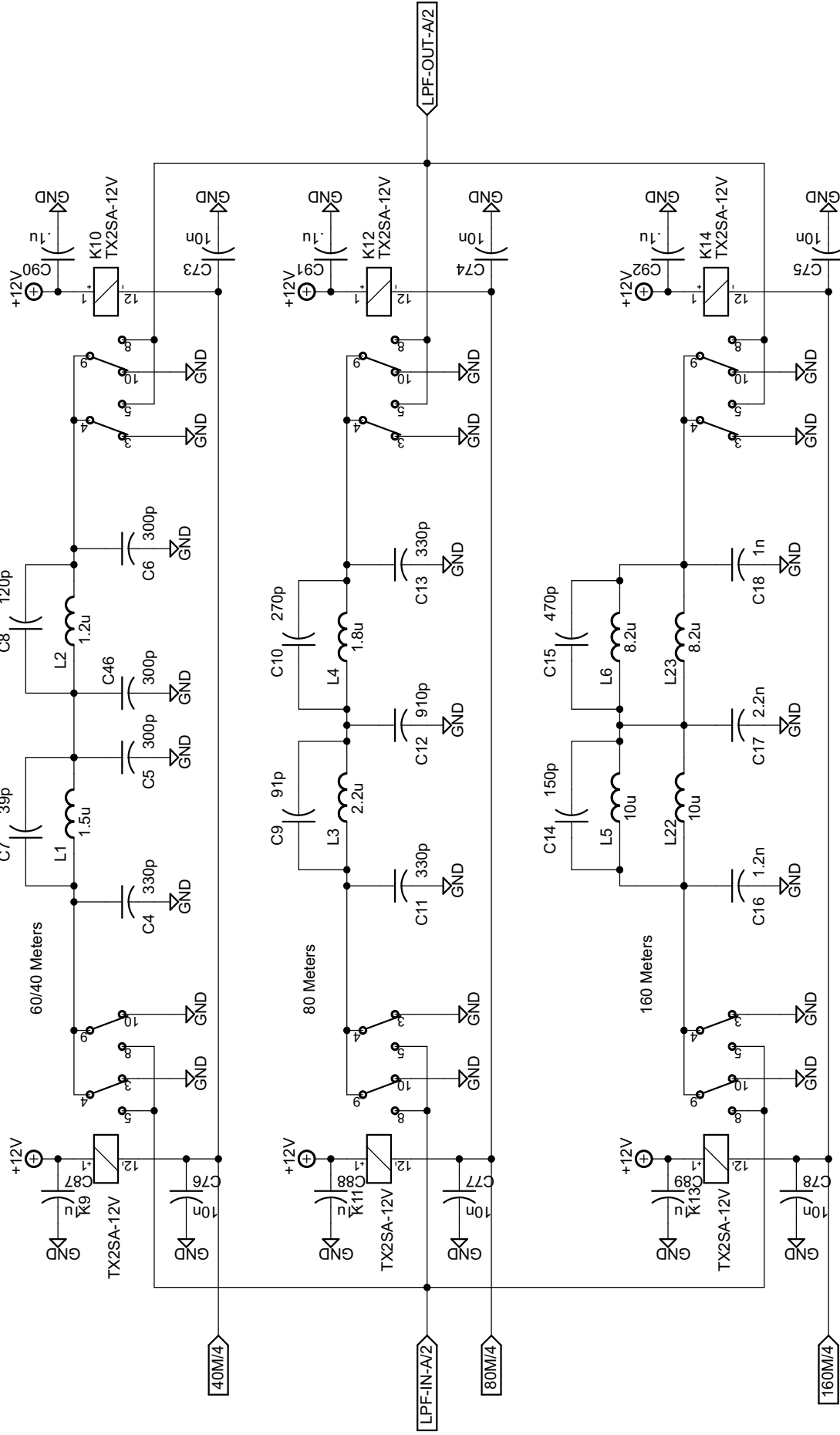

LOW FREQUENCY LPF BANK

Copyright FlexRadio Systems 2009

TITLE: PPA05 PC-0049 REV B

Document Number:

REV:

Physical order on board is: 60/40 M
 10 M
 80 M
 17/15 M
 160 M
 30/20 M
 6 M

All Coils this page are
 CoilCraft 1812 CS Series

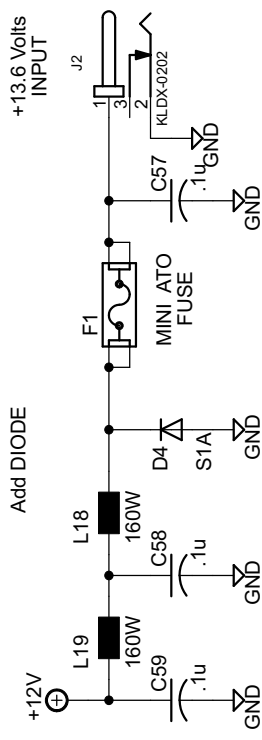

Add DIODE

- Flat Cable Assignments
- 1.) SPI5-LOAD
 - 2.) Ground
 - 3.) SPI5-CLK
 - 4.) +12V
 - 5.) SPI5-DATA
 - 6.) Ground
 - 7.) +5
 - 8.) +5
 - 9.) RF
 - 10.) Ground

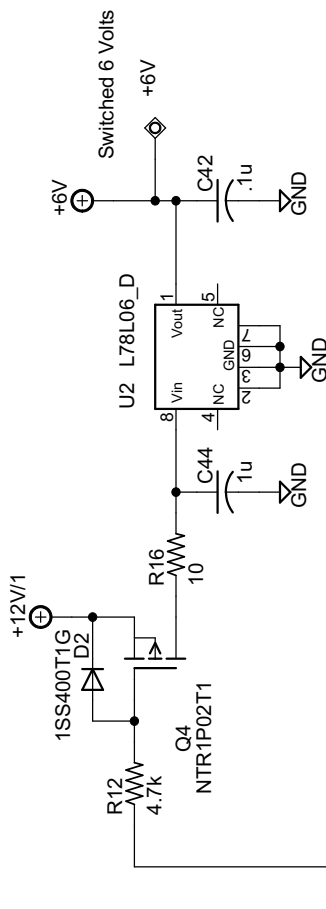
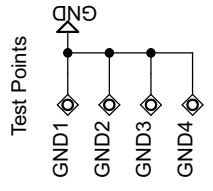
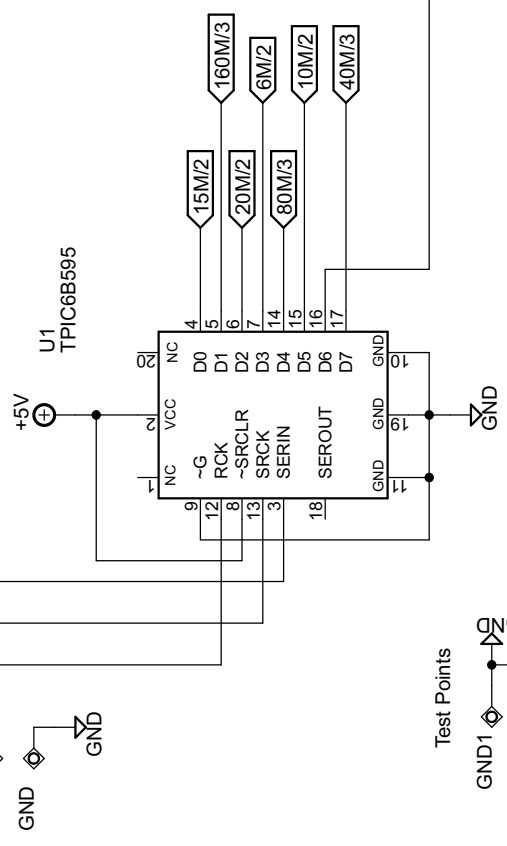
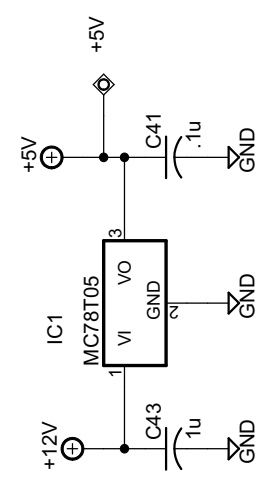
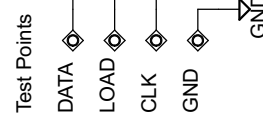
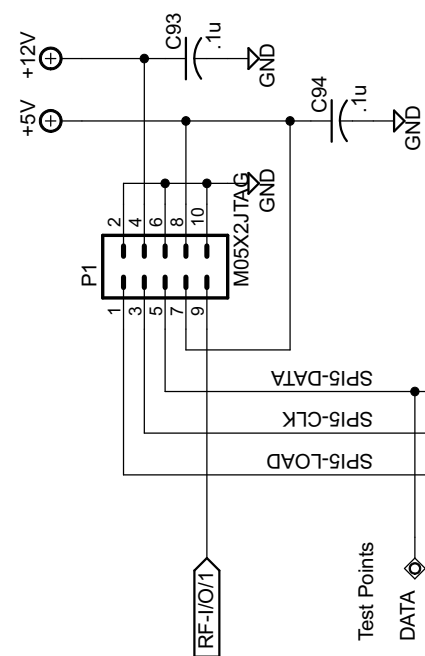

INTERCONNECT AND POWER

Copyright FlexRadio Systems 2009

TITLE: PPA05 PC-0049 REV B

Document Number:

REV:

Date: 3/25/2010 10:32:14 AM

Sheet: 4/4

Appendix "C"

PC Board Component View

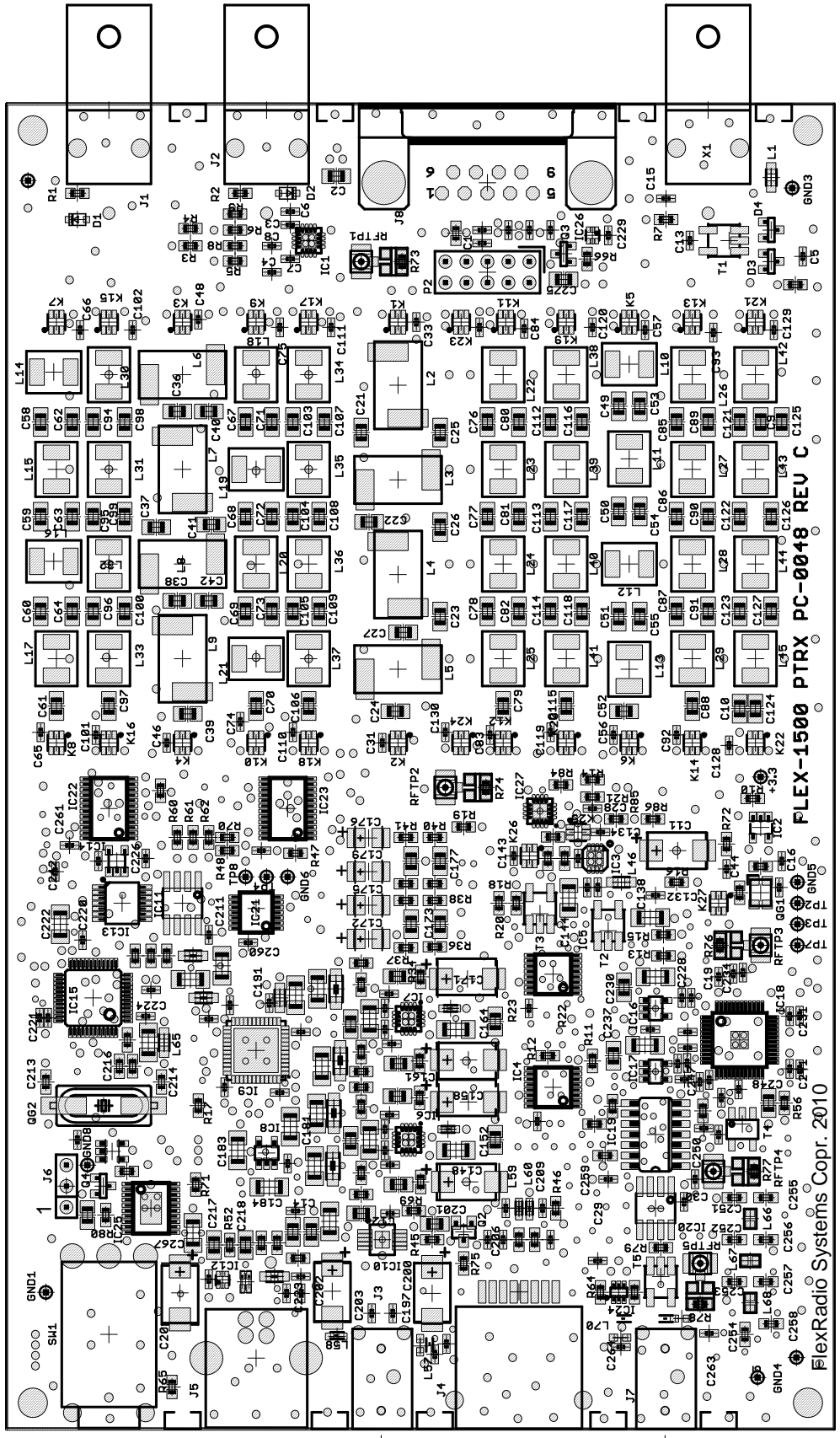

FLEX-1500 PTRX PC-0048 REV C

FlexRadio Systems Copr. 2010

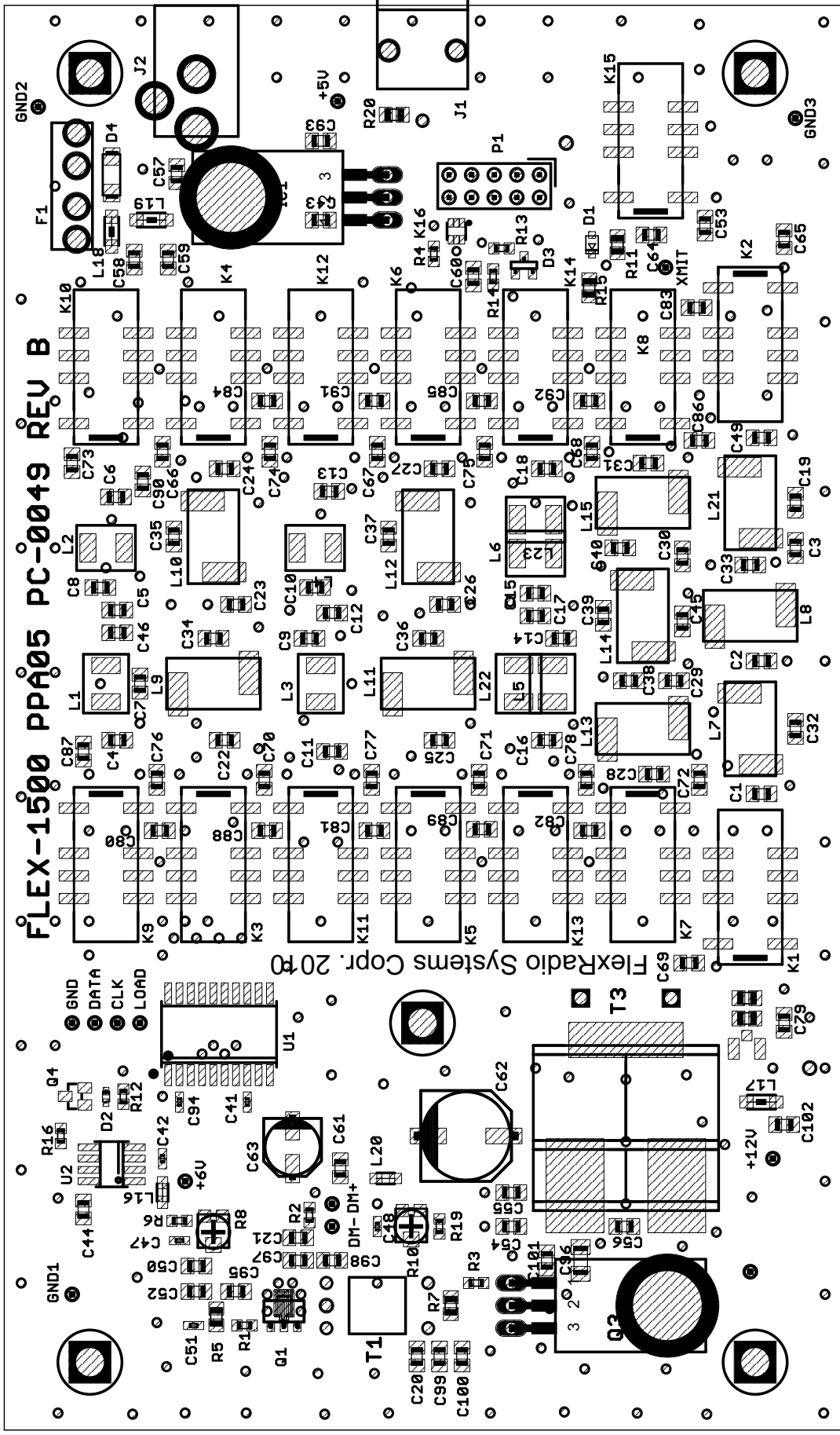

FLEX-1500 PPA05 PC-0049 REV B

FlexRadio Systems Copr. 2010

Appendix "D"

Test Points

TEST POINTS

I2C Bus

I2S Bus

3.3 Volts
(CPU Only)

3.3 Volts

SPI Bus (3.3 V)

1.8 Volts

5.0 Volts

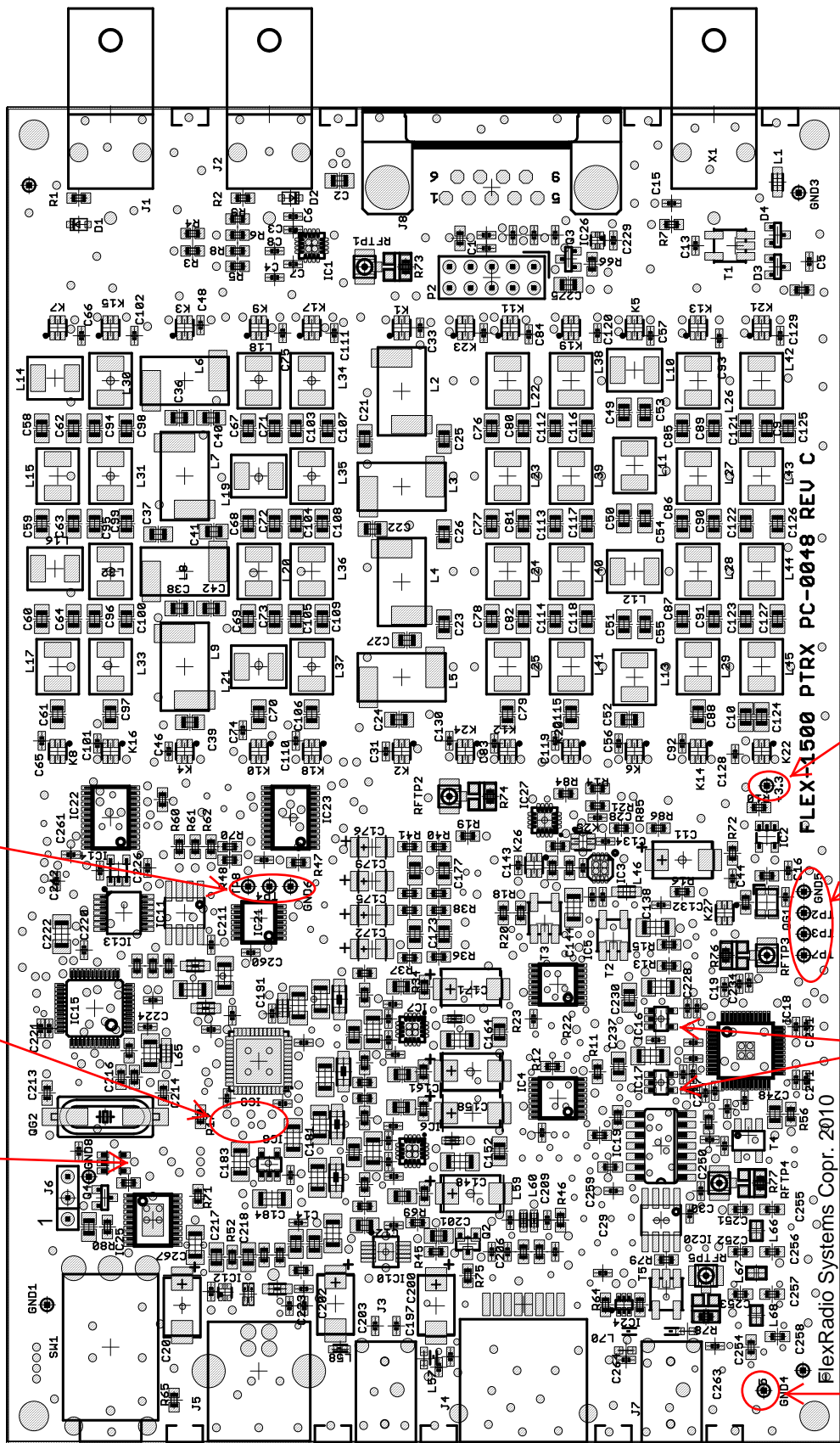

FLEX-1500 PTRX PC-0048 REV C

FlexRadio Systems Copr. 2010

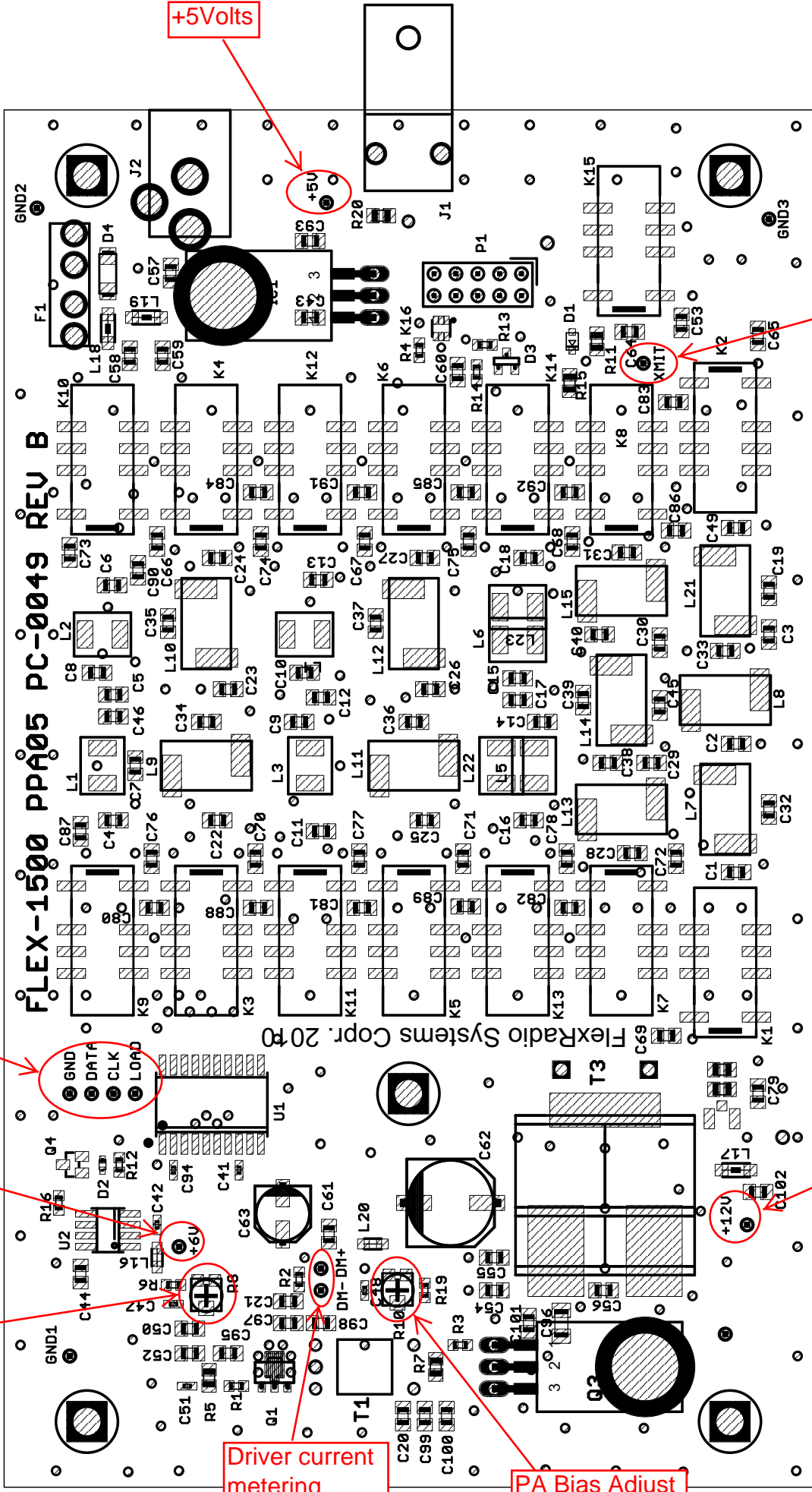

+5Volts

"XMIT" Test Point

SPI Bus (5 Volt)

+6 Volts (Keyed)

+12 Volts

Driver Bias Adjust

Driver current metering

PA Bias Adjust

Appendix "E"

Test Fixture

FLEXWIRE

DB-9 CONNECTOR

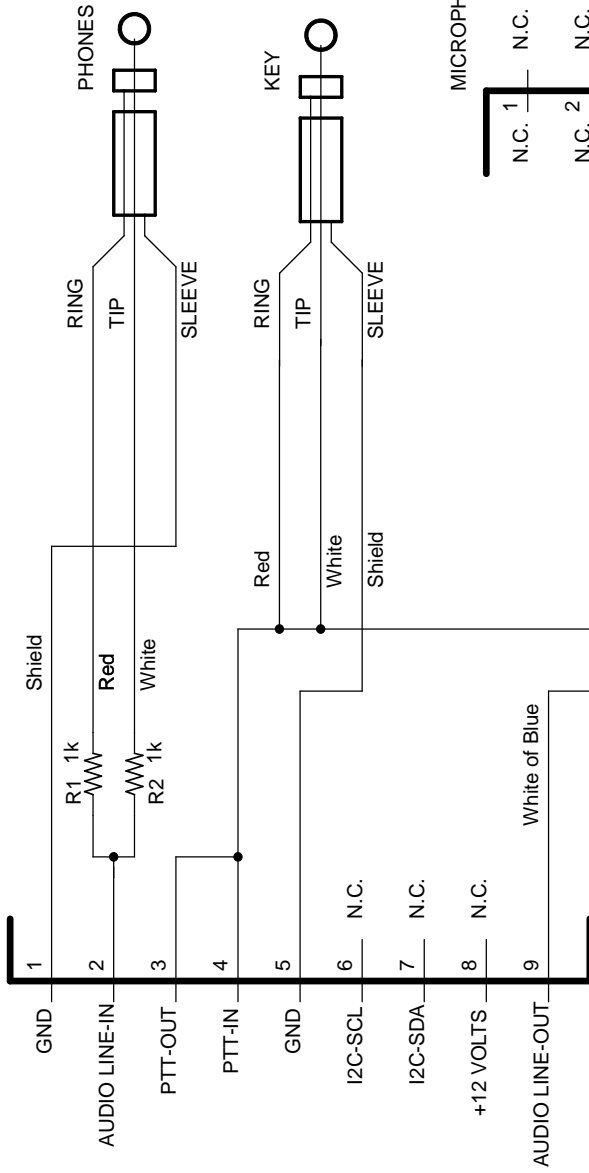

MICROPHONE -- RJ45

1	N.C.
2	N.C.
3	+5V
4	GND
5	MIKE
6	MIKE PTT
7	N.C.
8	N.C.

NOTES:

1. FlexWire Line-Out drives Microphone In
2. Speaker/Phones drive FlexWire Line-In
3. PTT-OUT from FlexWire drives FW-PTT-IN, MPTT, DOT, & DASH

FLEX-1500 TEST FIXTURE
Audio And Switching Test Cable

TITLE: FLEX-1500 Test Fixture

Document Number:

REV:

Date: 5/2/2010 8:37:59 PM

Sheet: 1/3

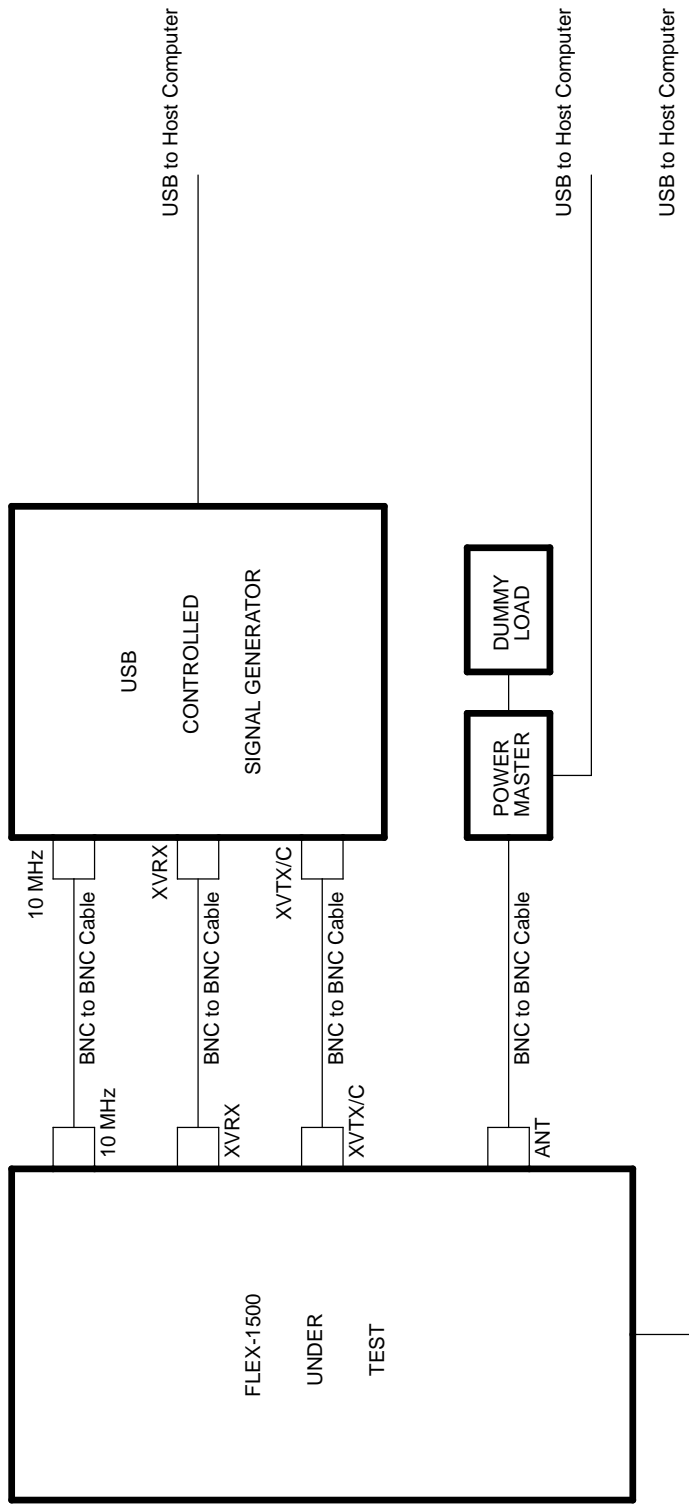

NOTES:

1. DDS SigGen drives 10 MHz input at 0 dBm
2. DDS SigGen drives XVRX, XVTX/C at -70 dBm through splitter
3. PowerMaster verifies RF power output

FLEX-1500 TEST FIXTURE
RF Connections

TITLE: FLEX-1500 Test Fixture

Document Number:

REV:

Date: 5/2/2010 8:37:59 PM

Sheet: 2/3

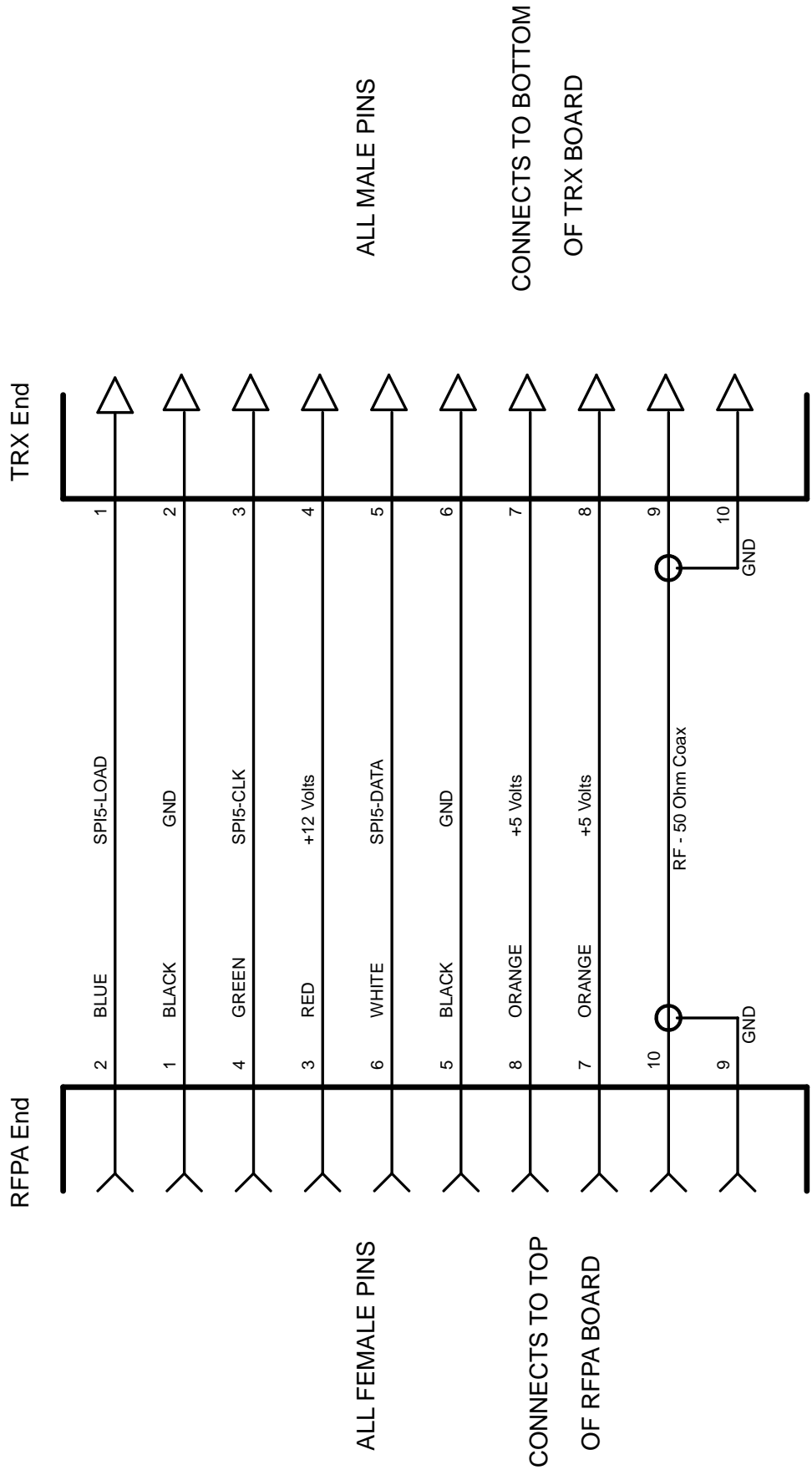

ALL FEMALE PINS

CONNECTS TO TOP OF TRX BOARD

ALL MALE PINS

CONNECTS TO BOTTOM OF RFPA BOARD

FLEX-1500 TEST FIXTURE
Board to Board Jumper Cable

TITLE: FLEX-1500 Test Fixture

Document Number:

REV:

Date: 5/2/2010 8:37:59 PM

Sheet: 3/3

Appendix "F"

Bill of Materials